

RELIANEERING

THE NEW WAY OF...
OF DOING CONDITION MONITORING

TRAINING

V 2 / 20200318

RESES.NET - VIEWER ROLE

OR

HOW TO WORK WITH RESES.NET AS A
VIEWER?

RESES.NET - VIEWER ROLE

OR

HOW TO WORK WITH RESES.NET AS A VIEWER?

- A. Understand the CBM process
- B. Get the information about machine status
- C. Look at the vibration
- D. Give a feedback
- E. Export data

CBM Definition

Document	Definition of the Condition-based maintenance (CBM)
ISO 13372	Maintenance performed as governed by condition monitoring programmes
DNVGL-CG-0052	CBM is a predictive maintenance form, based on and utilizing the information of an established condition monitoring programme
ABS Rules for survey after construction	A maintenance plan, conducted on a frequent or real-time basis, which is based on the use of Condition Monitoring to determine when part replacement or other corrective action is required.
Lloyd's Register Machinery Planned maintenance and Condition Monitoring	A systems approach to asset management which will include assessment of an asset's criticality and probability of failure, assessment of the consequences of asset failure and development of a strategy to minimise the risks associated with asset failure. This may include, for example, the condition monitoring tools deployed , company policy for spares procurement.

CM Program definitions

Document	Definition of the Condition Monitoring (CM) programme
ISO 13373-1	After selection of the equipment to be monitored, and determining the type of measurement system that is appropriate, it is recommended that a condition monitoring programme flowchart be developed. However, since each plant and each system is unique, the data flow should be customized to provide the maximum benefits.
DNVGL-CG-0052	A CM programme is the result of an evaluation of what and how machinery shall be monitored . It contains comprehensive information about all relevant parameters, components and personnel , related to condition monitoring.
ABS Rules for survey after construction	Preventative Maintenance Program (PMP) – A program that consists of Planned Maintenance and/or Condition Monitoring plans . CM - The use of various technologies to determine the condition of equipment, at a specific moment in time, using minimal or non-invasive means.

CBM Workflow

- Collect
- Transfer
- Store

- Machine Status
- Discovered Faults
- Recommendations to mitigate the risk of machine to fail.

- Accept / Reject recommendations
- Create notifications in CMMS
- Plan and execute

DATA

DATA ANALYSIS

MAINTENANCE

FEEDBACK

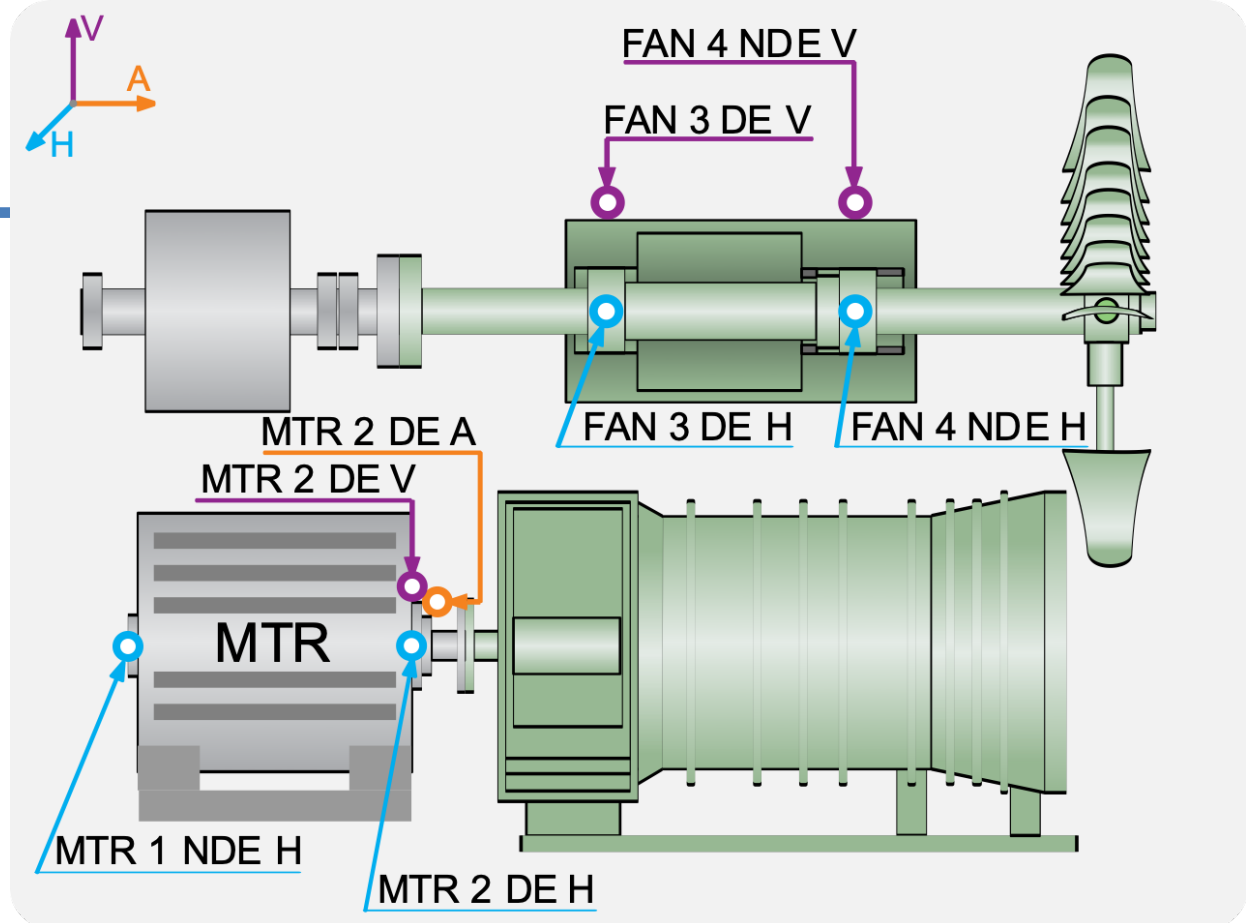

- Recommendation's status
- Findings

COLLECT DATA

- ▶ Turn On the Hotspot on the mobile
- ▶ CONNECT the Sensor to the CM Point's quick connect stud
- ▶ SCAN the RFID tag
- ▶ PRESS the Button
- ▶ DETACH the Sensor
- ▶ GO TO next Point and next Machine
- ▶ Wait all files to be transferred to the cloud and turn Off the HotSpot

The app home screen gives information about:

- Mobile device WiFi On and OFF
- HotSpot - On and OFF
- Speed to ReSES.net
- Time to data transfer to ReSES.net

The app connects to the ReSES.net and displays the last status and FL in overdue or due in next few days

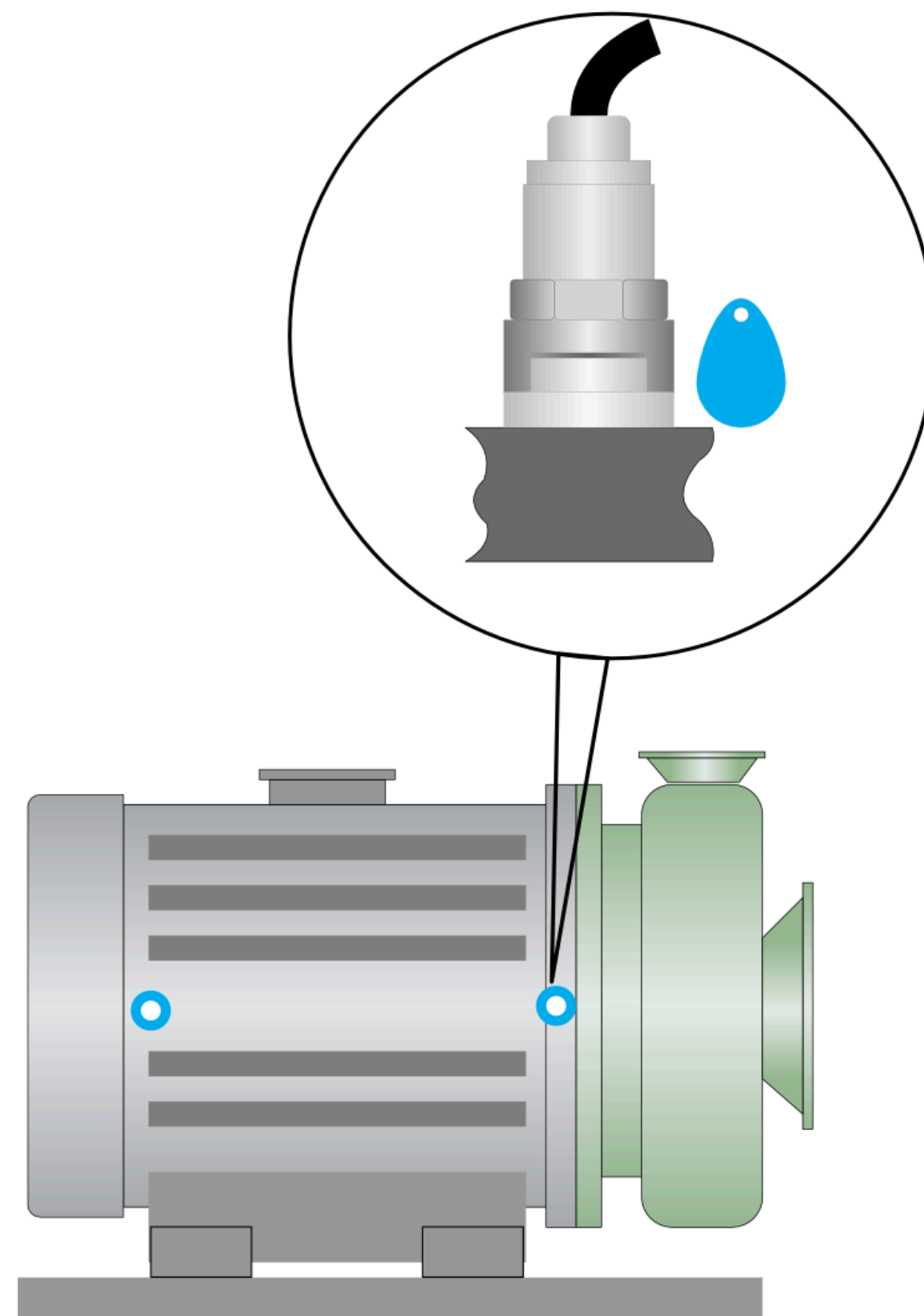

ReSES Communicator

Site	In Alarm	In Overdue
Copenhagen, DK	0	0
Gothenburg, SE	3	7
RESES 1	2	12

Current site: RESES 1 - RESES Shipping

Category	Count
Not Analyzed	97.5% (3)
Good	25% (2)
Acceptable	25% (2)
Attention	12.5% (1)
Unacceptable	0% (0)

ReSES Communicator

RESES 1 Hotel Plant SYSTEM FW

Functional Location: DEMO UNIT 1

Test 3 PCBs

TEST FW

Point	Vel 10-1kHz	Overdue in
MTR_1_NDE_H	10.243	-15 days
MTR_2_DE_H	10.033	-15 days
MTR_2_DE_V	1.379	-15 days

ReSES Communicator

Functional Location	Days in Overdue	Points in Overdue
Pump 25633	-316	1/2
TEST PM	-75	1/3
TEST FW	-13	1/2
DEMO UNIT 1	-15	3/3
Test 3 PCBs	-13	1/3
HFO Transfer Pump	-6503	1/3
SW Pump 2	-427	3/3
Test Pump 2	n/a	0/3
SW Pump 1	-406	2/2

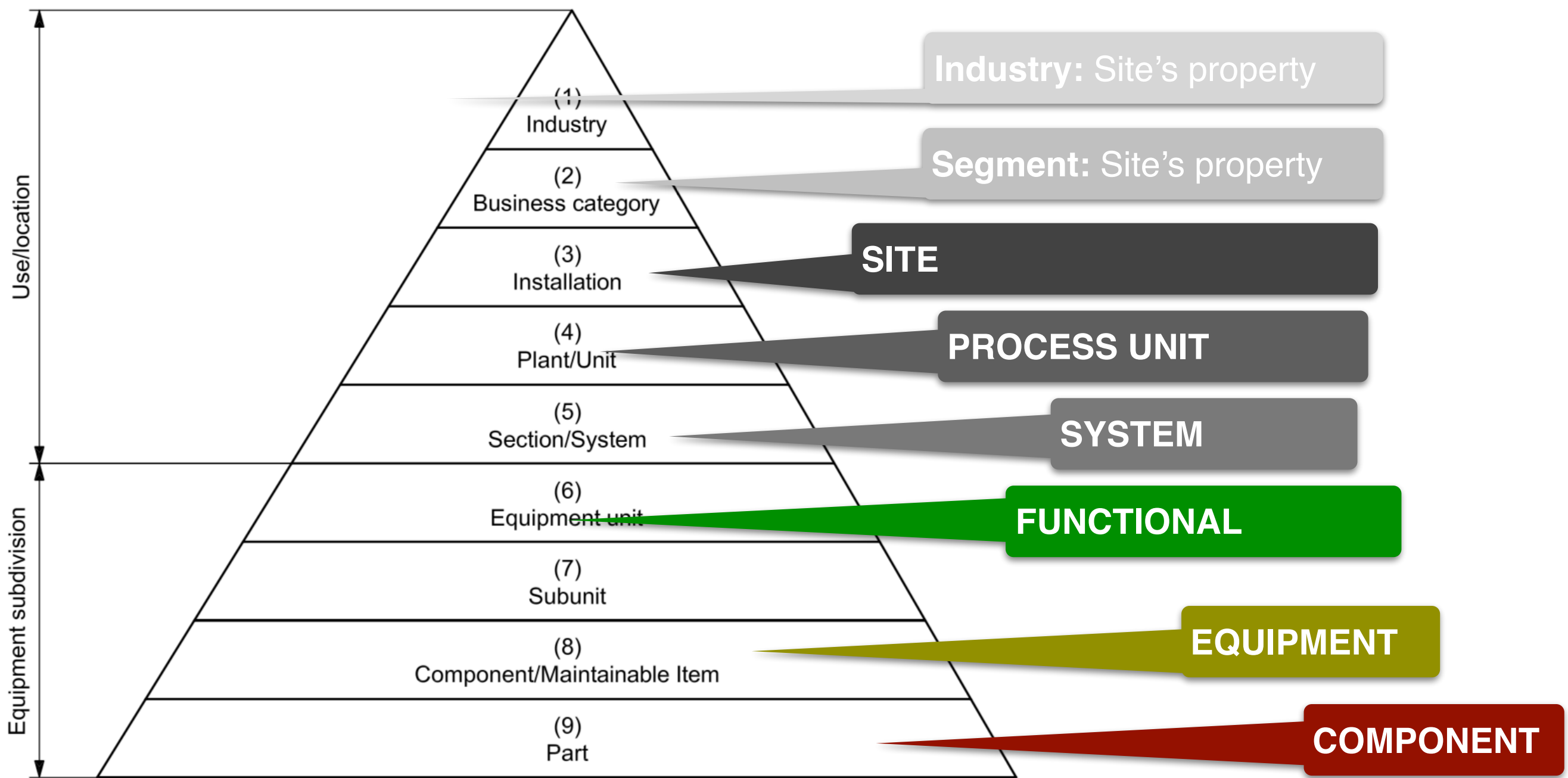
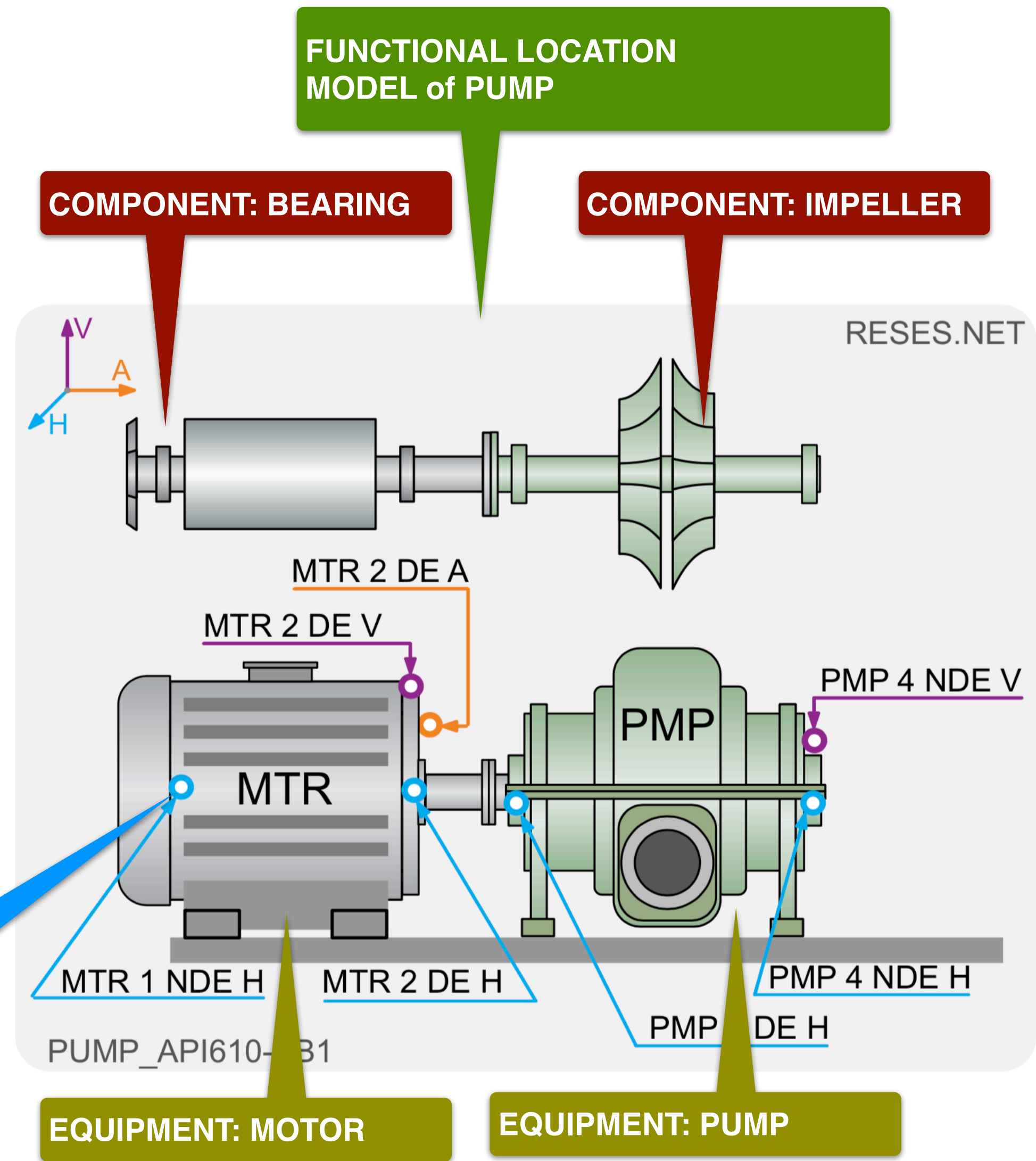

Figure 3 — Taxonomy

ISO 14224:2006 Taxonomy

CM POINT - location for data collection



ReSES.net CM MODELS

RELIANEERING AB RESES.NET

Model Group	Number of models
Pumps	57
Fans	24
Compressors	17
Gearboxes	8
Others	38
U type user spec	5
Z type ext data	9
Test units	4
Summary	162

Model ID	Name	Scheme	No of CM points	Price category
PMP_042	PUMP_VERTICAL_TANK_2		3	Short
PMP_043	PUMP_MULST_HOR_1A		7	Average
PMP_044	PUMP_MULST_HOR_1B		7	Average
PMP_045	PUMP_LRVAC_BELT_HOR_2		10	Long
PMP_046	PUMP_SCREW_HOR_6A		6	Average
PMP_047	PUMP_VERTICAL_BELT_1		5	Average

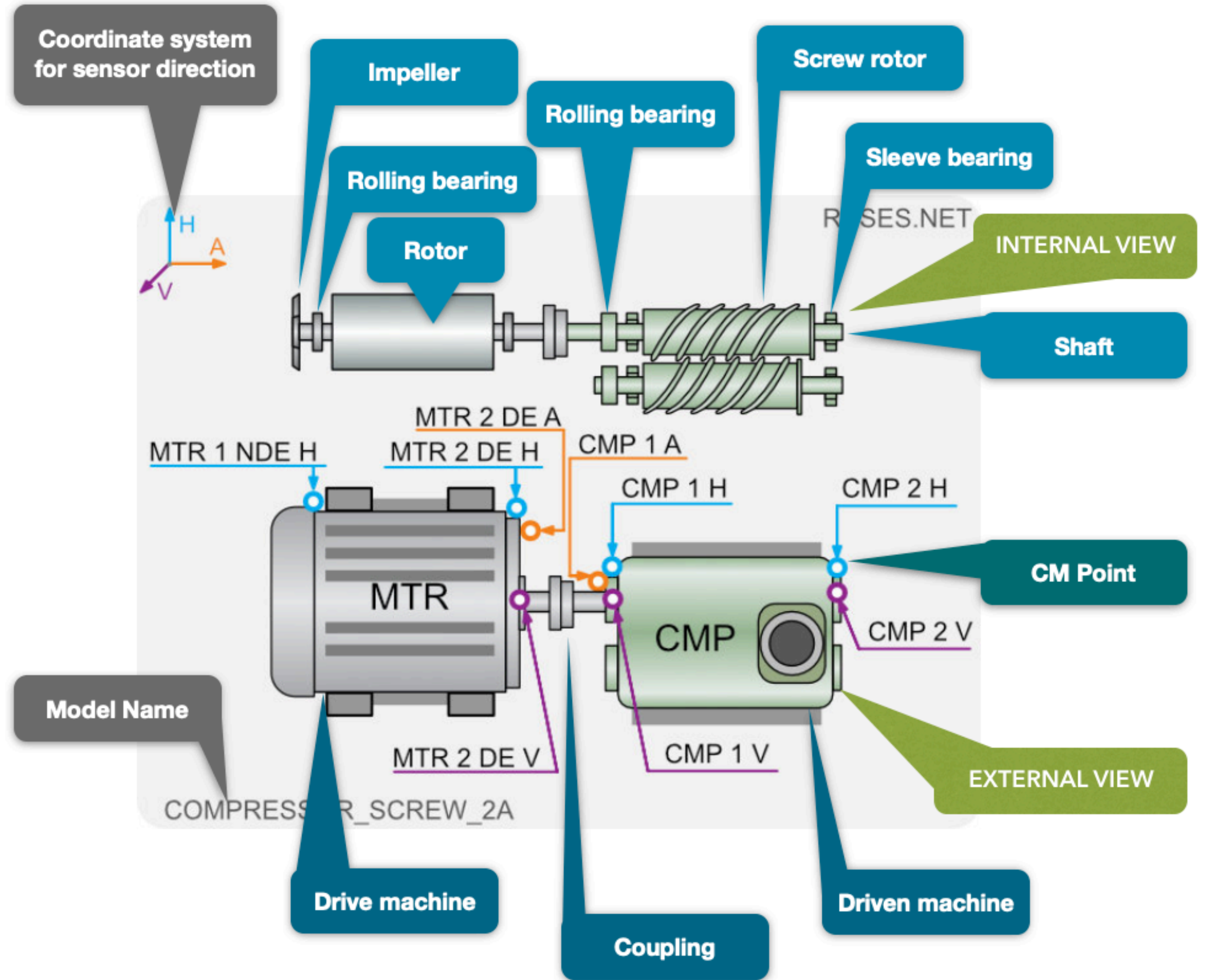

CM Status

The ReSES.net uses two different statuses:

- Functional Location status, based on analyzed data
- CM Point status, based on alarm levels

The **CM Point** status uses alarm levels that are specific for each point. The alarm sets initially are assigned per Functional Location and are the same for each **CM Point**, but can be edit at any time. Only the Builder has rights to change the CM Point alarm settings.

Some to the **CM Points** alarm's settings are calculated automatically based on the data.

The **Baseline** data are the first collected point's data and can be reset afterwards.

The **CM Deviation** is calculated after the fifth reading.

The **Functional Location** CM status category is:

- Good
- Acceptable
- Attention
- Not Acceptable

The categories **Attention** and **Not Acceptable** requires to have defined at least one **Recommended Action**.

Categories **Attention** and **Not Acceptable** require to have **Recommended Actions**.

The **CM Point** data status category is:

- Good
- Alarm Low
- Alarm Hi

The CM Point categories helps the Analyst quickly to find out possible faults.

The CM Point data alarms are triggered by:

- Levels - Low and Hi
- Change from the Baseline
- Change from the previous readings
- Reses CM Deviation

The ReSES.net CM deviation algorithm is similar to Standard deviation algorithm, but the new readings are evaluated first, before to be added to calculations.

The CM Point data are post- processed and presented in a table format. Every computed parameter is a single scalar value and four alarms. The user can see the following computed parameters per point:

Vibration velocity bands in mm/s RMS

10 to 1000 Hz

Below 1X

1X, 2X, 3X, 4X, 5X, 6X, 7X, 8X, 9X

Summary of 1X to 10X

Non Synchronous

Acceleration band in g RMS

1.5 to 3 KHz

1 to 5 kHz

5 to 12 KHz

Time waveform (TWF)

Overall g in RMS

Crest Factor

Number of peaks above standard deviation of the TWF

Skewness

Kurtosis

Functional Location Status

- Not Acceptable
- Attention
- Acceptable
- Good / OK

CM Point Status

- Alarm High
- Alarm Low
- Good

Support Status







- OK
- Attention
- In progress
- Completed
- Active
- Inactive
- No data

12.133	Alarm Hi
5.801	Alarm Low
1.234	Good

POINTS	VELOCITY [mm/s RMS]												ACCELERATION [g RMS]				TIME WAVE FORM						
	Points 9 / 9	Speed rpm	VEL 0.01-1 kHz	VEL <1X	VEL 1X	VEL 2X	VEL 3X	VEL 4X	VEL 5X	VEL 6X	VEL 7X	VEL 8X	VEL 9X*	VEL SUM 1-10X	VEL Non sync	ACC 1.5-3 kHz	ACC 1-5 kHz	ACC 4.5-12 kHz	Smart Envelop sE	TWF Overall g	TWF Crest Factor	TWF Transient Index	TWF Skew
MTR_1_NDE_H 5-Nov-18 13:35:29	3113.000	5.783	1.251	5.774	0.137	0.069	0.036	0.009	0.034	0.021	0.013	0.007	5.777	0.181	1.708	2.024	2.254	2.128	4.956	4.105	0.022	0.015	2.970
MTR_1_NDE_V 5-Nov-18 13:35:36	3113.000	1.632	0.449	1.459	0.241	0.057	0.035	0.011	0.019	0.032	0.010	0.009	1.481	0.642	1.642	3.146	5.732	21.804	6.379	4.717	0.041	0.027	3.153
MTR_2_DE_H 5-Nov-18 13:35:36	3113.000	4.273	0.544	5.774	0.114	0.088	0.034	0.108	0.033	0.017	0.008	0.007	4.247	0.463	1.504	2.372	2.105	12.173	3.189	3.941	0.022	0.056	2.915
MTR_2_DE_V 5-Nov-18 13:37:22	3113.000	0.888	0.895	0.130	0.322	0.061	0.020	0.067	0.031	0.023	0.010	0.005	0.362	0.804	1.595	1.919	2.268	11.571	3.042	4.656	0.049	0.112	2.876
MTR_2_DE_A 5-Nov-18 13:38:33	3113.000	0.767	0.357	0.594	0.338	0.037	0.011	0.039	0.023	0.013	0.008	0.013	0.686	0.230	0.490	0.849	2.460	8.576	2.651	3.970	0.021	0.014	2.711
FAN_3_DE_H 5-Nov-18 13:38:27	3113.000	1.091	1.044	0.524	0.302	0.056	0.144	0.850	0.045	0.081	0.020	0.013	1.059	0.243	0.145	0.215	1.217	4.552	1.255	4.034	0.019	0.001	2.899
FAN_3_DE_V 5-Nov-18 13:38:31	3113.000	1.435	0.480	1.339	0.171	0.039	0.050	0.440	0.021	0.039	0.019	0.017	1.423	0.186	0.158	0.235	0.711	1.970	0.763	4.321	0.026	0.010	2.977
FAN_4_NDE_H 5-Nov-18 13:38:16	3113.000	1.377	0.361	1.259	0.218	0.078	0.060	0.416	0.033	0.062	0.096	0.083	1.355	0.229	0.073	0.183	0.680	1.700	0.704	4.551	0.033	-0.001	3.024
FAN_4_NDE_V 5-Nov-18 13:39:38	3113.000	0.569	0.144	0.466	0.194	0.040	0.017	0.056	0.041	0.024	0.039	0.069	0.519	0.231	0.086	0.113	0.409	1.043	0.447	4.527	0.033	0.011	2.977

SYMBOLS AND ICONS in ReSES.net

The ReSES.net platform Viewer workflow is organized in three major steps, and four support subprocesses.

- 1. Mission 
- 2. Status 
- 3. Analyzer 
- Noteboard 
- Builder 
- Exchanger 
- Account 

Mission: The Viewer selects a Site. The Site is the user mission to find out what is going on and act.

Status: The user has access to all machine (Functional Location) analyzed statuses. This is the main dashboard.

Analyzer: The Viewer can look at the vibration data used in the last analysis.

The screenshot shows the ReSES.net Viewer interface. On the left is a navigation sidebar with icons for Mission, Status, Analyser, Noteboard, Builder, Exchanger, and Account. The main content area is divided into several sections:

- Summary Statistics:** A table comparing '2019-11-24 05:35:22' (Last login) with 'Viewer' metrics.

Metric	Value
Last login	2019-11-24 05:35:22
Last session	1m
Last active	0m
Total functional locations	334
Price category Short	199
Total equipments	897
Price category Average	49
Total analysis for last 2 years	6604
Price category Long	31
Price category Extra	55
- Table:** A table listing sites with columns for Company, Site, ReSHI, Not Analysed, Good, Acceptable, Attention, Not Acceptable, Data in Overdue, Analysis in Overdue, and Total FL.

Company	Site	ReSHI	Not Analysed	Good	Acceptable	Attention	Not Acceptable	Data in Overdue	Analysis in Overdue	Total FL
RESES	RESES 1	7.11	4	4	7	1	0	15	4	19
St Eriks	Hjalbo	4.73	0	1	1	0	0	2	0	2
Statnett	Statnett DS	4.85	0	1	6	1	1	0	0	9
Stena Recycle AB	Halstahammar	4.73	0	0	3	0	0	0	0	3
Stena Recycle AB	Halmstad	4.35	0	2	0	1	1	4	0	4
Sunde Group	Sundolitt AB	4.70	0	4	12	4	0	14	0	23
Tenneco	Tenneco Göteborg AB	5.65	0	2	2	0	0	0	0	4
- Summary of Functional Locations (FL):** A donut chart showing the status of 322 locations.

Status	Percentage	Count
Good	45%	145
Accept	43.2%	139
Attention	9.9%	32
Not Acceptable	-	-
- RESES - RESES 1:** A donut chart showing the status of 16 locations.

Status	Percentage	Count
Good	37.5%	6
Accept	43.8%	7
Attention	18.8%	3
Not Acceptable	-	-
- Map:** A Google Map showing the location of Gothenburg, Sweden, with a red pin and various map controls.

LOGIN to ReSES.net

Open a browser (Safari, FireFox or Chrome).

- Type reses.net
- Enter the mail that you used to be registered.
- Enter your password.
- Select the Role.

Press **Contact** to send a question.

In case of forgotten password, press **Forgot Password** and you will get a mail with a link that is valid for 30 min.

Use the link to go to **Account** and change your password.

reses.net

ReSES CM Cloud [Contact](#)

User email
support@relianceering.com

Password

Select User Role
✓ Viewer
Analyst
Supervisor
Builder

[Forgot password](#) [Login](#)

reses.net

ReSES CM Cloud [Contact](#)

User email
@.com

Password

Select User Role
Viewer

[Forgot password](#) [Login](#)

You will receive mail to access account !

reses.net

IG ReSES system ADSBBHub - Free ADS-B Data Exchange and

CONTACT US [<< BACK](#)

Your Name
First name, Last name

Your Email
Email

Subject
Subject

Message
Message

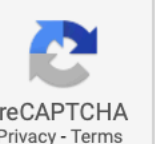
I'm not a robot  reCAPTCHA
Privacy - Terms

[Send Message](#)

support@reses.net

ReSES forgot password

To:

To access ReSES system please click on this link:

<http://www.reses.net/account.php?sessid=533068609708443862>

Link will be valid 30min !

BR,
ReSES

ReSES.net MISSION

The ReSES.net **Mission** center is designed for a companies with more than one **Site**.

The **Viewer** can select a **Site** and further to check the status of the functional locations (**FL**).

At glance the Viewer finds at glance the following info:

1. **ReSHI** - Site health index computed based on the **FL** status and **FL**'s criticality. **ReSHI** is in range from 2.5 to 10, where 10 means all machines are in **Good** condition.
2. **Not Analyzed** - Number of **FLs** with collected data, but still pending to be analyzed.
3. **Good to Not Acceptable** - Number of **FLs** with the column condition
 - **Data in Overdue** - Number of **FLs** with not collected data on time
 - **Analysis in Overdue** - Number of **FLs** with not completed analysis on time
 - **Total FL** - All **FLs** in the **Site**. It is a sum of: Not Analyzed, Good, Acceptable, Attention, Not Acceptable, Not collected.

The screenshot displays the ReSES.net Mission center interface. On the left is a sidebar with navigation icons for Mission, Status, Analyser, Noteboard, Builder, Exchanger, and Account. The main content area is divided into several sections:

- ReSES Viewer**: A summary card showing account information.

ReSES Viewer	Viewer
2019-11-24 05:35:22 Last login	1m Last session
	0m Last active
334 Total functional locations	199 Price category Short
897 Total equipments	49 Price category Average
6604 Total analysis for last 2 years	31 Price category Long
	55 Price category Extra
- Table**: A list of sites with columns for Company, Site, ReSHI, Not Analyzed, Good, Acceptable, Attention, Not Acceptable, Data in Overdue, Analysis in Overdue, and Total FL. A callout 'Select a Site' points to the 'RESES 1' row.
- Summary of Functional Locations (FL)**: A donut chart for the entire company showing 322 total FLs.

Status	Percentage	Count
Good	43.2%	139
Accept	9.9%	32
Attention	-	-
Not Acceptable	-	-
Total	-	322
- RESES - RESES 1**: A pie chart for the selected site showing 16 total FLs.

Status	Percentage	Count
Good	37.5%	6
Accept	43.8%	7
Attention	18.8%	3
Not Acceptable	-	-
Total	-	16
- Map**: A map showing the location of the selected site, with a callout 'Site location' pointing to a red pin near Gothenburg.
- History FL status pie chart**: A callout pointing to a pie chart showing the historical status of functional locations for the selected site.

Tip:

Use History buttons to compare the Site CM Status.

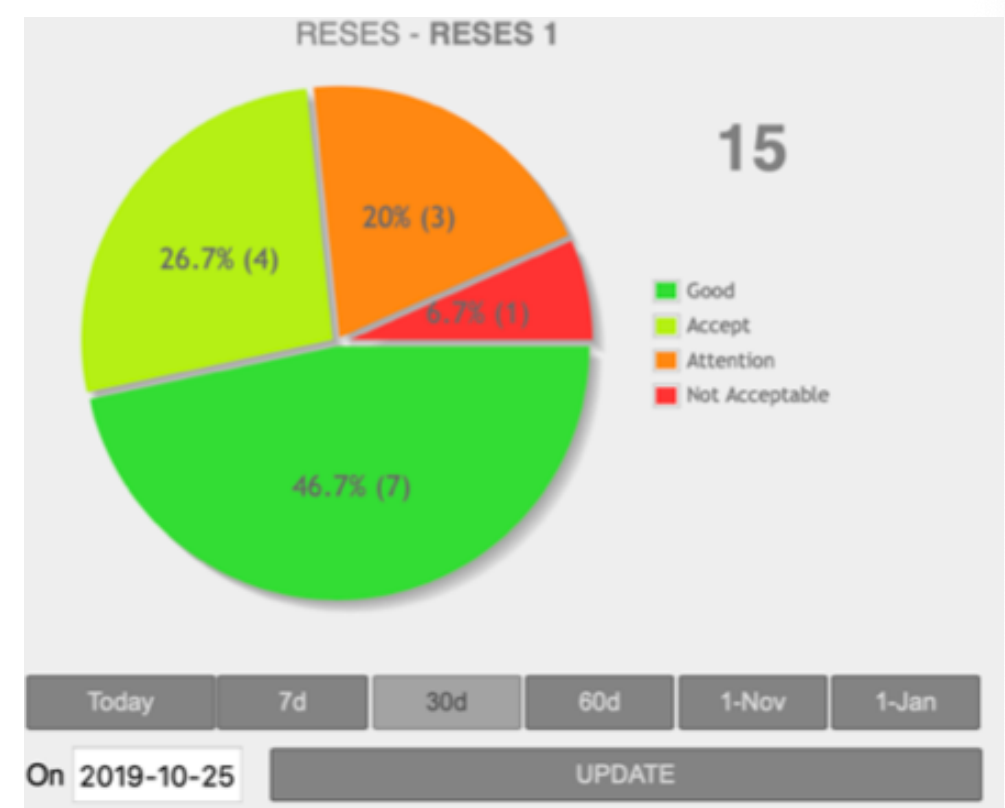
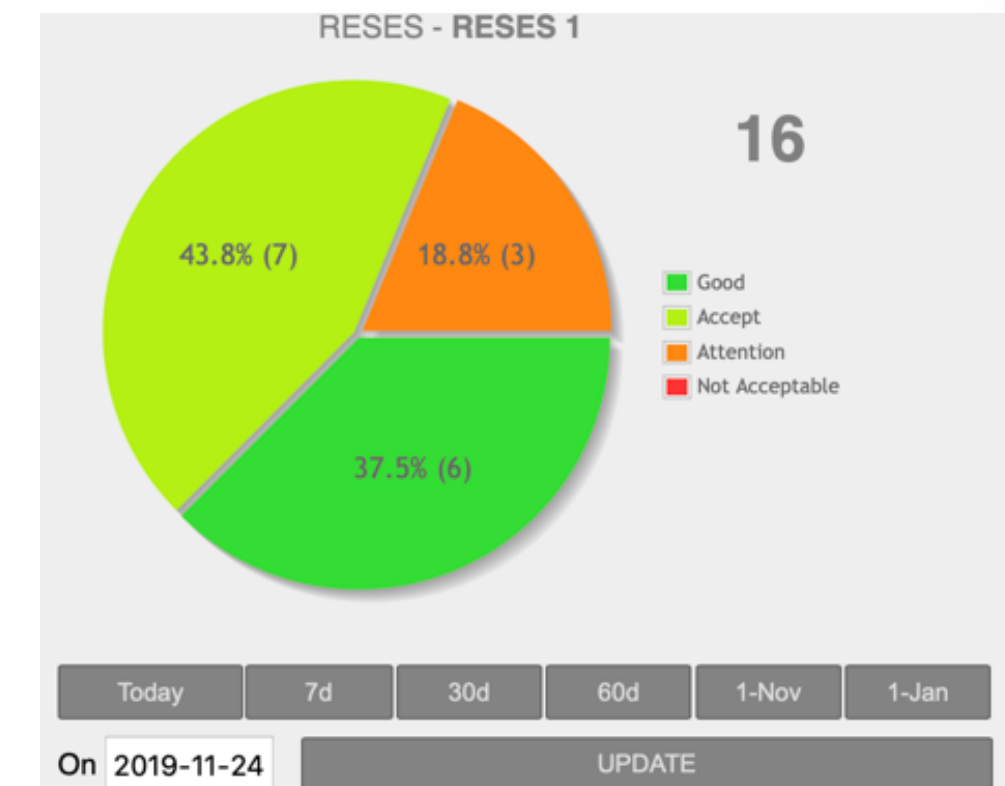

ReSES Viewer

2019-11-24 06:35:07
Last login

334
Total functional locations

897
Total equipments

6604
Total analysis for last 2 years

Viewer

0m
Last session

0m
Last active

199
Price category Short

49
Price category Average

31
Price category Long

55
Price category Extra

Company	Site	ReSHI	Not Analysed	Good	Acceptable	Attention	Not Acceptable	Data in Overdue	Analysis in Overdue	Total FL
RESES	RESES 1	7.11	4	4	7	1	0	15	4	19
St Eriks	Hjalbo	4.73	0	1	1	0	0	2	0	2
Statnett	Statnett DS	4.85	0	1	6	1	1	0	0	8
Stena Recycle AB	Hallstahammar	4.73	0	0	3	0	0	0	0	3
Stena Recycle AB	Halmstad	4.35	0	2	0	1	1	4	0	7
Sunde Group	Sundolitt AB	4.70	0	4	12	4	0	14	0	28
Tenneco	Tenneco Göteborg AB	5.85	0	2	0	0	0	0	0	2

Summary of Functional Locations (FL)

Status	Percentage	Count
Good	45%	145
Accept	43.2%	139
Attention	9.9%	32
Not Acceptable	1.9%	6

On 2019-11-24 UPDATE

RESES - RESES 1

Status	Percentage	Count
Good	46.7%	7
Accept	26.7%	4
Attention	20%	3
Not Acceptable	6.7%	1

On 2019-10-25 UPDATE

ReSES.net STATUS

The Status is the dashboard only for the selected Site.

The Viewer can do the following:

- FL's CM Status and recommendations
- Review the last report
- Check the FL history
- Generate the last report in a PDF format
- See the FL data collection status.
- See the Review (feedback) status
- Generate a the FL's statuses trend for the last 3 months from a selected day.
- Narrow the FL list using filters
- Re-order the list using columns Ascending and Descending order.

The screenshot shows the ReSES.net STATUS dashboard for site RESES - RESES 1. The dashboard includes a bar chart for 'Site FL Status' showing the distribution of Functional Locations (FL) across different status categories: Not Analyzed (25%), Good (25%), Acceptable (43.8%), Attention (6.3%), and Not Acceptable (0%). A line chart shows the 'Site FL Status trend' over a 3-month period. A table lists individual FLs with columns for Process Unit, System, FL Name, FL Group, Last Status, Data Collected, Analysed on, Recommendations, Feedback, Review, Analysed by, New Data, and Due in days. Callouts highlight various features: 'Sort' and 'Filters' for the bar chart; 'Sort by status' for the table; 'No new Data for this FL' for the trend chart; 'No feedback' and 'The Review is not started' for specific FL rows; 'The report review is completed' for another row; 'New data are uploaded, before the analysis to be completed.' for a row with a green checkmark; and 'Once one CM Point out of 3 has been collected.' for a row with a red status and a '3/3' indicator. The dashboard also features a sidebar with navigation icons for Mission, Status, Analyser, Noteboard, Builder, Exchanger, and Account, and a footer with the Relianeering logo and website URL.

Tip:

Use the filters to narrow down the list of machines.

Type “pump” in FL name and all Functional location containing “pump” in the name will be selected.

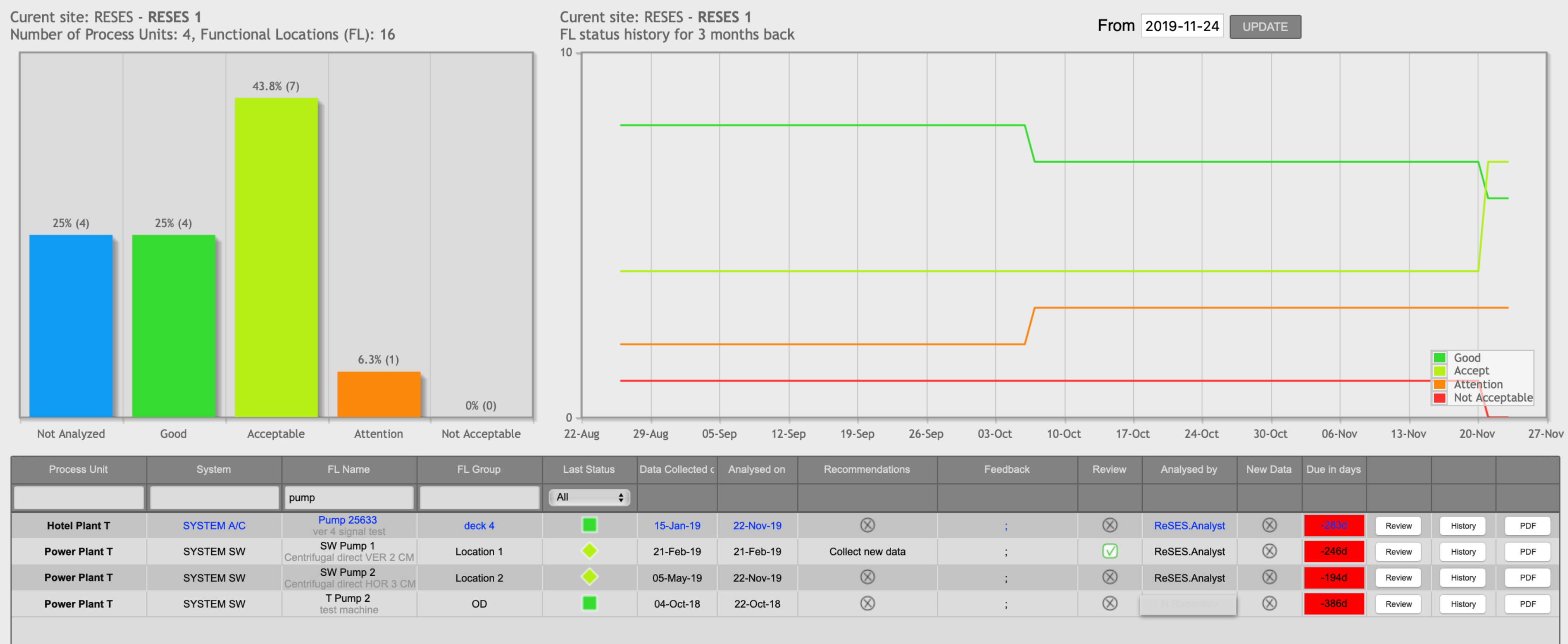

Tip:

Use the column Sort to narrow down the list of machines.

Narrow down the list by selecting the FL Status.

Order by Data Collection Overdue.

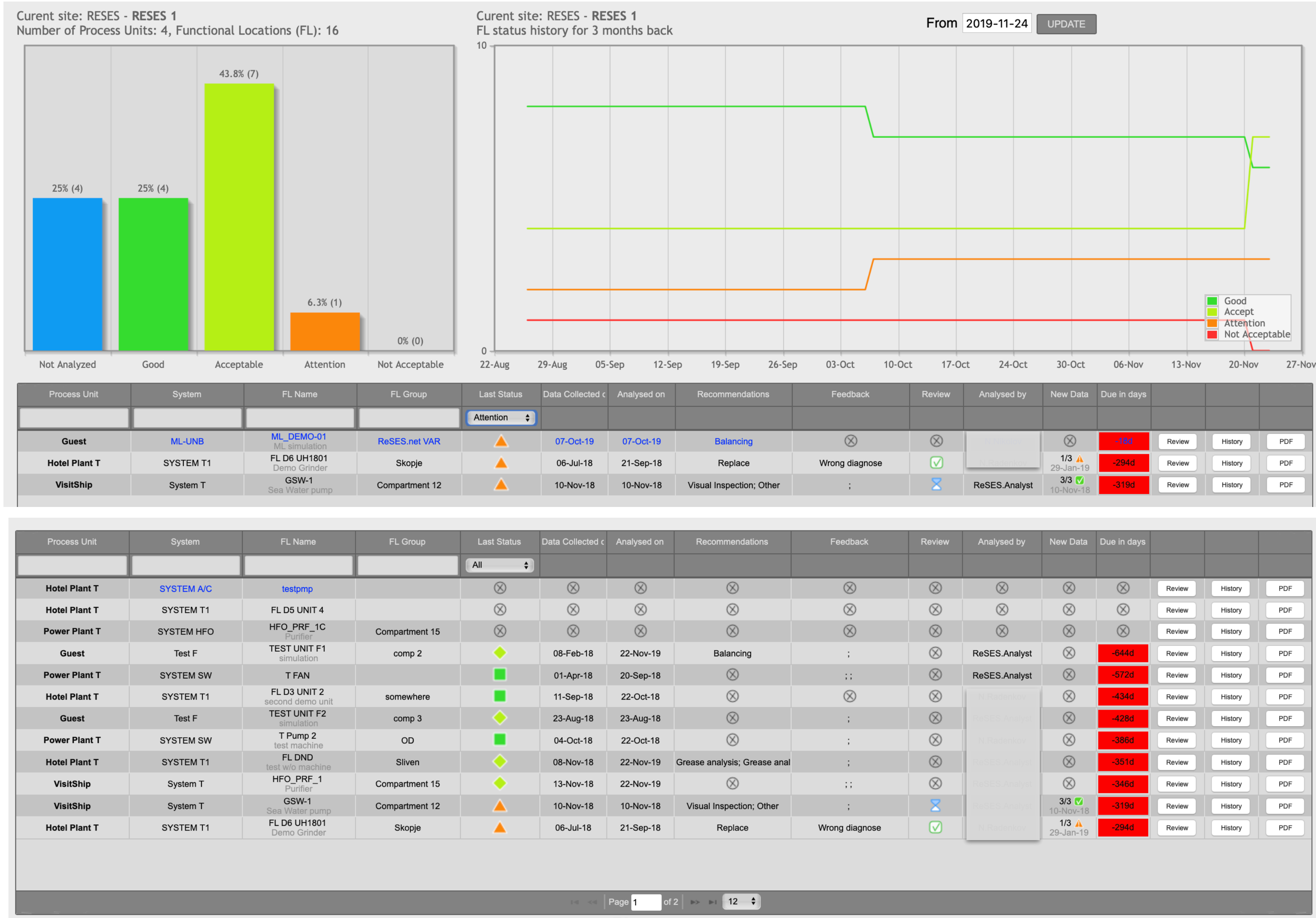

ReSES.net STATUS \ History

Status board / History:

- Once the user press History button of the selected FL, he/she can see the statuses in graphical and table format
- In the graph the user can position the mouse over the status icon and will get who has completed the analysis and when.
- The table gives historical information about analysis
 - Last Analysis** - date when the analysis has been completed
 - Status** - icon of the aggregate equipment statuses
 - Data Alarms** - icon of the aggregate data alarms
 - Data collected** - Date when the data has been collected. NOTE: All measurements are in time window of one hour
 - Last Recommendations** - aggregate recommended actions from the last analysis
 - Feedback** - aggregate feedback to the last analysis The user has a view of the selected Site and category's percentage in the Site.
 - Notes** - aggregated additional notes to the recommended actions

Functional Location History

RESES \ RESES 1 \ Hotel Plant T \ SYSTEM T1 \ FL D6 UH1801 Demo Grinder

Analysed on	Status	Data Alarms	Data Collected on	Recommendations	Feedback	Notes
21-Sep-18	▲	⊘	6-Jul-18	Replace	Wrong diagnose	Replace rotor
14-Jun-18	■	⊘	24-Apr-18			
24-Apr-18	◆	⊘	24-Apr-18	Balancing		Check all bolts
2-Apr-18	▲	⊘	16-Mar-18	Collect new data		
13-Mar-18	▲	⊘	13-Mar-18	Collect new data		Check that machine operates, before to collect data
13-Mar-18	◆	⊘	13-Mar-18	Overhaul machine		Check soft foot
12-Mar-18	◆	⊘	12-Mar-18	Balancing; Balancing		Check soft foot; Check soft foot
10-Mar-18	◆	⊘	10-Mar-18	Balancing		Please check balancing
9-Mar-18	◆	⊘	9-Mar-18	Balancing		Please balance

Sun Nov 24 2019 08:48:03 GMT+0200 (EET) ver 2.18

RELIANEERING Simple. Easy. Smart.

ReSES.net STATUS \ Review

The Review Process gives an opportunity the Viewer to provide a valuable feedback to the CM Specialists and the CM Specialist to be updated by planned activities.

Step One: Recommended actions has been reviewed and planned

The Viewer opens the Review and Agree (Accept) or Reject the recommended action. It means the user has reviewed the report and planned actions.

Step Two: Recommended actions has been executed

The Viewer provides a generic feedback at the equipment level. The feedback can be free text or selected from a predefined texts.

Once the Viewer that has provided the feedback can change it. Once the feedback is provided, other Viewers can't edit it.

Equipment Report - GSW-1 Sea Water pump

Equipment / Component	Fault Date	Fault Name	Severe	Fault Notes	Recommended Action	Priority	Recommendation Note	Savings [usd]	Found by	Agree
EL MOTOR / EL MOTOR - GENERIC SYSTEM COMPONEN	10-Nov-18 12:47	Vibration interference	Med		Visual Inspection	Med		0	ReSES.Analyst	n/a yes no
PUMP - CENTRIFUGAL / PMP IMPELLER - PUMP 5 vanes C	10-Nov-18 12:48	Flow turbulence	Med		Other	Low	Change the operational regime	0	ReSES.Analyst	⊗

Feedback Form:

Equipment: EL MOTOR (), PUMP - CENTRIFUGAL ()

Last Status: (Green Diamond), (Red Triangle)

Feedback: (Dropdown menu)

What is your feedback:

- Recommendations are planned
- Recommendations are performed
- Recommendations are rejected
- Correct diagnose
- Wrong diagnose
- Helpful advise

Technical Diagram: PUMP_VERTICAL_3 showing MTR 1 NDE R, MTR 2 DE A, MTR 2 DE R, and PMP.

Component Details:

- Desc: EL Motor
- Speed: 3575.00rpm
- Power: 125.00kW
- Components:
 - EL MOTOR: GENERIC SYSTEM COMPONENT
 - FAN COOLING: FAN 7 blades GENERIC
 - MTR 1 NDE BRG: DGBB 6213 C3 SKF
 - ROTOR: EM rotor EM rotor GENERIC
 - STATOR: EM 60 Hz Stator 60 Hz GENERIC
 - MTR 2 DE BRG: DGBB 6213 C3 SKF

SYMBOLS AND ICONS in ReSES.net \ Last Report

Tip:

Use PDF button to generate the last report in a PDF file.

Do not forget to download on your hard drive.

The Fault and Recommended Action format is <selected by catalogue - <CM Specialists notes>

RELIANEERING
Simple. Easy. Smart.

FUNCTIONAL LOCATION CM STATUS REPORT

Company	Site
RESES	RESES 1

Process Unit	System	Functional Location	Description	CMMS ID
VisitShip	System T	GSW-1	Sea Water pump	

Analysed on	CM Status	Analysed by
2018-11-10 12:48:24	ATTENTION	ReSES.Analyst

Equipment	CM Status	CMMS ID
EL MOTOR	ACCEPTABLE	
PUMP - CENTRIFUGAL	ATTENTION	

Equipment	Component	Fault	Sev	Recommended Action	Pri
EL MOTOR	EL MOTOR	Vibration interference	Med	Visual Inspection -	Med
PUMP - CENTRIFUGAL	PMP IMPELLER	Flow turbulence -	Med	Other - Change the operational regime	Low

The Viewer role has the same tools as Analyst role to look at the collected data.

The **Viewer sees the last analyzed data.** If there are new data, they will be visualized in the trend only, but the spectra will not be available till the analysis is completed.

The screenshot displays the ReSES.net ANALYZER interface with several key components and callouts:

- Filters** and **Sort** callouts point to the top navigation area.
- Select a Functional Location** callout points to the table below.
- Functional Location CM Information** callout points to the trend graph.
- Open spectra**, **Open rE Graph**, and **Turn On/OFF alarm types** callouts point to the bottom navigation bar.
- Functional Location Data dashboard** callout points to the overall data view.

Process Unit	System	FL Name	FL Group	Last Status	New Data	Review
Guest	ML-UNB	ML_DEMO-01 ML simulation	ReSES.net VAR	▲	⊗	⊗
Guest	Test F	TEST UNIT F1 simulation	comp 2	◆	⊗	⊗
Guest	Test F	TEST UNIT F2 simulation	comp 3	◆	⊗	⊗
Hotel Plant T	SYSTEM A/C	Pump 25633 ver 4 signal test	deck 4	■	⊗	⊗
Hotel Plant T	SYSTEM A/C	testpmp		⊗	⊗	⊗
Hotel Plant T	SYSTEM T1	FL D1 1809 TEST Device HS	Gothenburg	■	1/3 ▲ 09-Oct-19	⊗
Hotel Plant T	SYSTEM T1	FL D2 UNIT 1 Test Grinder	Gothenburg	■	3/3 ✓ 15-Nov-19	✓
Hotel Plant T	SYSTEM T1	FL D3 UNIT 2 second demo unit	somewhere	■	⊗	⊗
Hotel Plant T	SYSTEM T1	FL D5 UNIT 4		⊗	⊗	⊗
Hotel Plant T	SYSTEM T1	FL D6 UH1801 Demo Grinder	Skopje	▲	1/3 ▲ 29-Jan-19	✓

POINTS		VELOCITY [mm/s RMS]													ACCELERATION [g RMS]			TIME WAVE FORM						
Points	Group in 1 min	Speed rpm	VEL 0.01-1 kHz	VEL <1X	VEL 1X	VEL 2X	VEL 3X	VEL 4X	VEL 5X	VEL 6X	VEL 7X	VEL 8X	VEL 9X*	VEL SUM 1-10X	VEL Non sync	ACC 1.5-3 kHz	ACC 1-5 kHz	ACC 4.5-12 kHz	Smart Envelop sE	TWF Overall g	TWF Crest Factor	TWF Transient Index	TWF Skew	TWF Kurtosis
MTR_1_NDE_H	7-Oct-19 13:46:14	3200.000	8.724	8.693	0.092	0.358	0.079	0.020	0.045	0.032	0.036	0.084	0.035	0.395	0.644	0.063	0.129	0.018	1.445	0.256	5.887	0.763	0.017	3.065
MTR_2_DE_H	7-Oct-19 13:45:26	3200.000	15.997	15.964	0.172	0.451	0.084	0.024	0.033	0.046	0.019	0.040	0.072	0.501	0.910	0.092	0.126	0.030	3.280	0.445	7.393	4.762	0.061	2.477
MTR_2_DE_V	7-Oct-19 13:45:51	3200.000	9.541	9.306	0.062	0.374	0.022	0.051	0.068	0.145	0.057	0.059	0.038	0.425	0.757	0.108	0.215	0.020	4.949	0.343	15.000	6.667	-0.213	10.209

The trend analysis is looking at the deviation of one parameters single value, over the time.

The trend can have two types of alarms alarms:

1. Absolute - level
2. Relative - deviations

The **Deviation alarm** are:

- Baseline - from a set of data assigned asa baseline.
- From last measurement - change.
- Statistical - above 5 measurements.

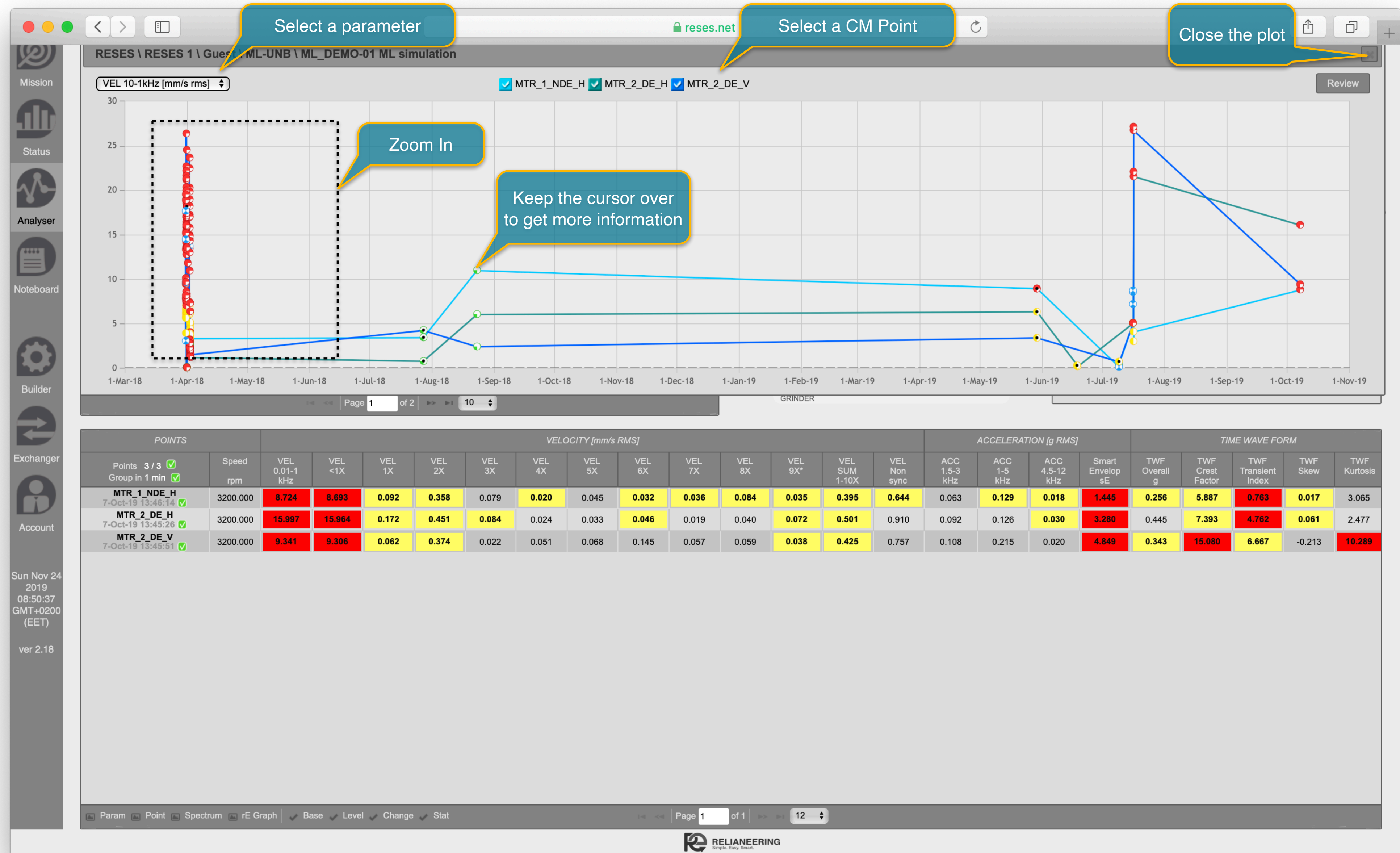

The ReSES.net computes 22 parameters per CM Point.

- Overall ISO 10-1000 Hz
- Flow instability
- Unbalance and resonance
- Misalignment
- Misalignment and Rotating looseness
- Misalignment and Rotating looseness
- Pump Impeller issues
- Pump Impeller issues
- Pump Impeller issues
- Pump Impeller issues
- Rolling bearings
- Interference and Bearing issues
- Interference and Bearing issues
- Rolling bearings and Gears and Cavitation and Fan impellers
- Rolling bearings and Gears and Cavitation
- Rolling bearings and Gears
- Rolling bearings and Gears
- Overall status
- TWF impacts
- TWF impacts
- TWF signal quality
- Bearings and gears

POINTS		VELOCITY [mm/s RMS]													ACCELERATION [g RMS]				TIME WAVE FORM				
Points 9 / 9 ✔ Group in 5 min ✔	Speed rpm	VEL 0.01-1 kHz	VEL <1X	VEL 1X	VEL 2X	VEL 3X	VEL 4X	VEL 5X	VEL 6X	VEL 7X	VEL 8X	VEL 9X*	VEL SUM 1-10X	VEL Non sync	ACC 1.5-3 kHz	ACC 1-5 kHz	ACC 4.5-12 kHz	Smart Envelop sE	TWF Overall g	TWF Crest Factor	TWF Transient Index	TWF Skew	TWF Kurtosis
MTR_1_NDE_H 5-Nov-19 13:36:09 ✔	3113.000	5.783	1.251	5.774	0.137	0.069	0.036	0.099	0.034	0.021	0.013	0.007	5.777	0.181	1.708	2.024	4.504	17.130	4.956	4.105	0.022	0.056	2.970
MTR_1_NDE_V 5-Nov-19 13:35:36 ✔	3113.000	1.632	0.449	1.459	0.241	0.057	0.035	0.011	0.019	0.032	0.010	0.009	1.481	0.642	1.642	3.146	5.732	21.804	6.379	4.717	0.041	0.027	3.153
MTR_2_DE_H 5-Nov-19 13:36:36 ✔	3113.000	4.273	0.544	4.243	0.114	0.088	0.034	0.108	0.033	0.017	0.008	0.007	4.247	0.463	1.504	2.372	2.105	12.173	3.189	3.941	0.022	0.056	2.915
MTR_2_DE_V 5-Nov-19 13:37:22 ✔	3113.000	0.888	0.895	0.130	0.322	0.061	0.020	0.067	0.031	0.023	0.010	0.005	0.362	0.804	1.595	1.919	2.268	11.571	3.042	4.656	0.049	0.112	2.876
MTR_2_DE_A 5-Nov-19 13:36:59 ✔	3113.000	0.767	0.357	0.594	0.338	0.037	0.011	0.039	0.023	0.013	0.008	0.013	0.686	0.230	0.490	0.849	2.460	8.576	2.651	3.970	0.021	0.014	2.711
FAN_3_DE_H 5-Nov-19 13:38:27 ✔	3113.000	1.091	1.044	0.524	0.302	0.056	0.144	0.850	0.045	0.081	0.020	0.013	1.059	0.243	0.145	0.215	1.217	4.552	1.255	4.034	0.019	0.001	2.899
FAN_3_DE_V 5-Nov-19 13:38:51 ✔	3113.000	1.435	0.480	1.339	0.171	0.039	0.050	0.440	0.021	0.039	0.019	0.017	1.423	0.186	0.158	0.235	0.711	1.970	0.763	4.321	0.026	0.010	2.977
FAN_4_NDE_H 5-Nov-19 13:39:16 ✔	3113.000	1.377	0.361	1.259	0.218	0.078	0.060	0.416	0.033	0.062	0.096	0.083	1.355	0.229	0.073	0.163	0.680	1.700	0.704	4.551	0.033	-0.001	3.024
FAN_4_NDE_V 5-Nov-19 13:39:38 ✔	3113.000	0.569	0.144	0.466	0.194	0.040	0.017	0.056	0.041	0.024	0.039	0.069	0.519	0.231	0.086	0.113	0.409	1.043	0.447	4.527	0.033	0.011	2.977

Trend alarms when absolute and relative alarms are turned ON

- Level - ON.
- Baseline - ON
- Change ON
- Statistical - ON

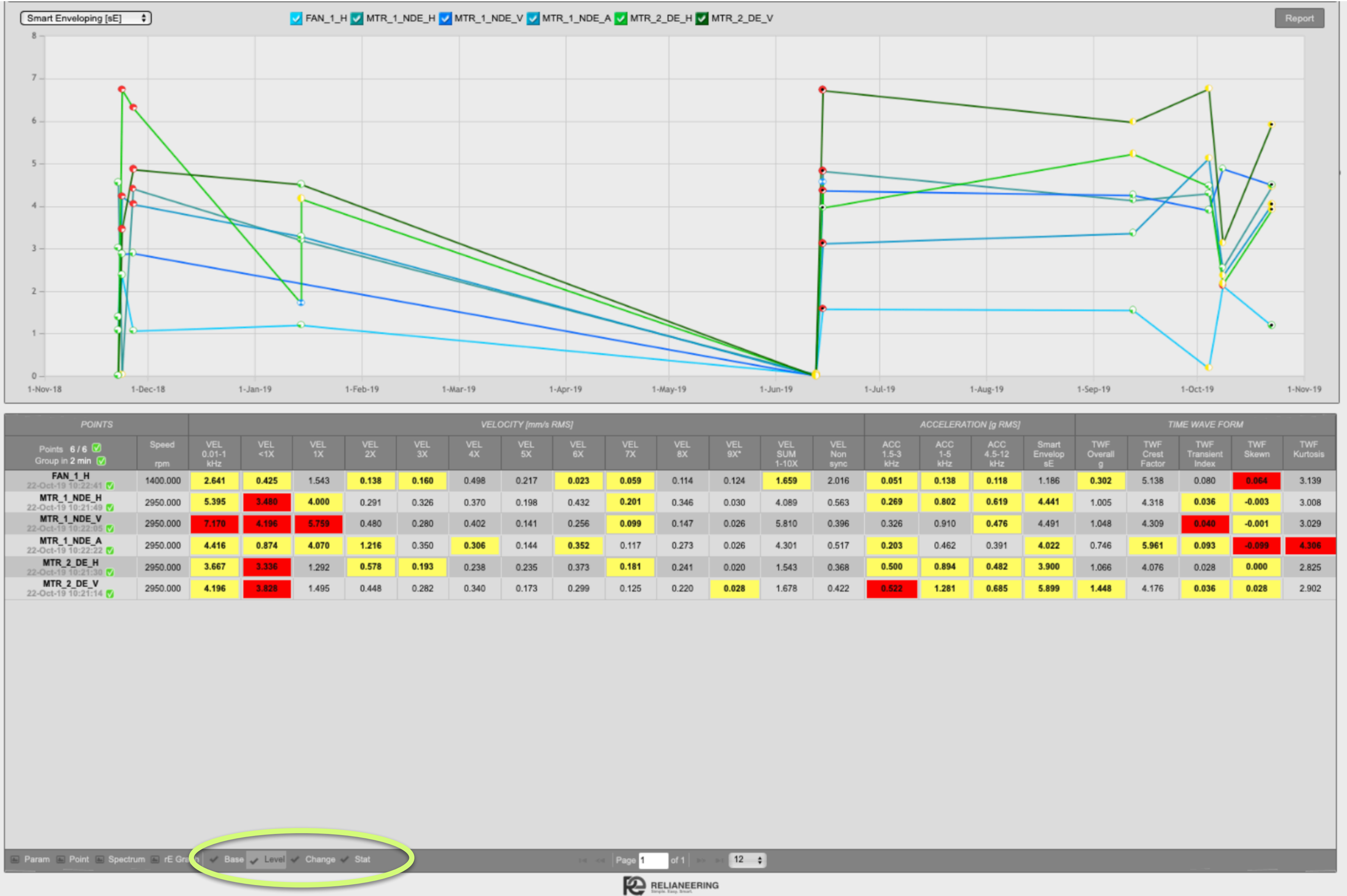

Level alarms (ISO).

- **Level - ON.**
- Baseline - OFF
- Change - OFF
- Statistical - OFF

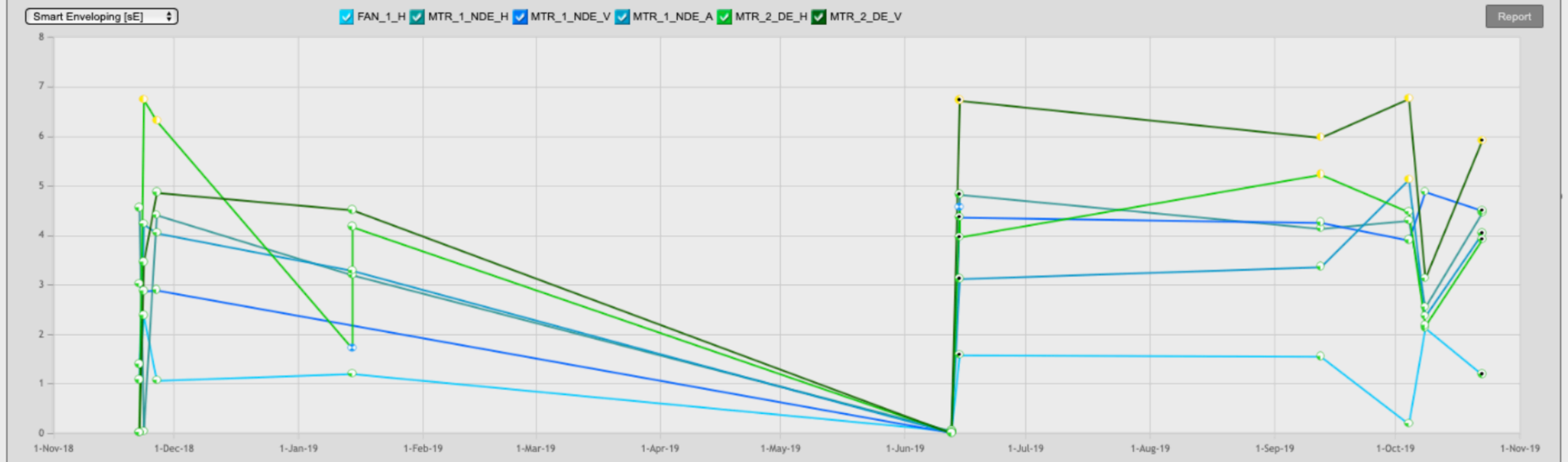

POINTS		Speed rpm	VELOCITY [mm/s RMS]												ACCELERATION [g RMS]				TIME WAVE FORM					
Points	Group in 2 min		VEL 0.01-1 kHz	VEL <1X	VEL 1X	VEL 2X	VEL 3X	VEL 4X	VEL 5X	VEL 6X	VEL 7X	VEL 8X	VEL 9X*	VEL SUM 1-10X	VEL Non sync	ACC 1.5-3 kHz	ACC 1-5 kHz	ACC 4.5-12 kHz	Smart Envelop sE	TWF Overall g	TWF Crest Factor	TWF Transient Index	TWF Skewn	TWF Kurtosis
FAN_1_H	22-Oct-19 10:22:41	1400.000	2.641	0.425	1.543	0.138	0.160	0.498	0.217	0.023	0.059	0.114	0.124	1.659	2.016	0.051	0.138	0.118	1.186	0.302	5.138	0.080	0.064	3.139
MTR_1_NDE_H	22-Oct-19 10:21:48	2950.000	5.395	3.480	4.000	0.291	0.326	0.370	0.198	0.432	0.201	0.346	0.030	4.089	0.563	0.269	0.802	0.619	4.441	1.005	4.318	0.036	-0.003	3.008
MTR_1_NDE_V	22-Oct-19 10:22:05	2950.000	7.170	4.196	5.759	0.480	0.280	0.402	0.141	0.256	0.099	0.147	0.026	5.810	0.396	0.326	0.910	0.476	4.491	1.048	4.309	0.040	-0.001	3.029
MTR_1_NDE_A	22-Oct-19 10:22:22	2950.000	4.416	0.874	4.070	1.216	0.350	0.306	0.144	0.352	0.117	0.273	0.026	4.301	0.517	0.203	0.462	0.391	4.022	0.746	5.961	0.093	-0.099	4.306
MTR_2_DE_H	22-Oct-19 10:21:30	2950.000	3.667	3.336	1.292	0.578	0.193	0.238	0.235	0.373	0.181	0.241	0.020	1.543	0.368	0.500	0.894	0.482	3.900	1.066	4.076	0.028	0.000	2.825
MTR_2_DE_V	22-Oct-19 10:21:14	2950.000	4.196	3.828	1.495	0.448	0.282	0.340	0.173	0.299	0.125	0.220	0.028	1.678	0.422	0.522	1.281	0.685	5.899	1.448	4.176	0.036	0.028	2.902

Param Point Spectrum rE Group **Base** Level Change Stat

Changes from the last measurement.

- Level - OFF.
- Baseline - OFF
- **Change - ON**
- Statistical - OFF

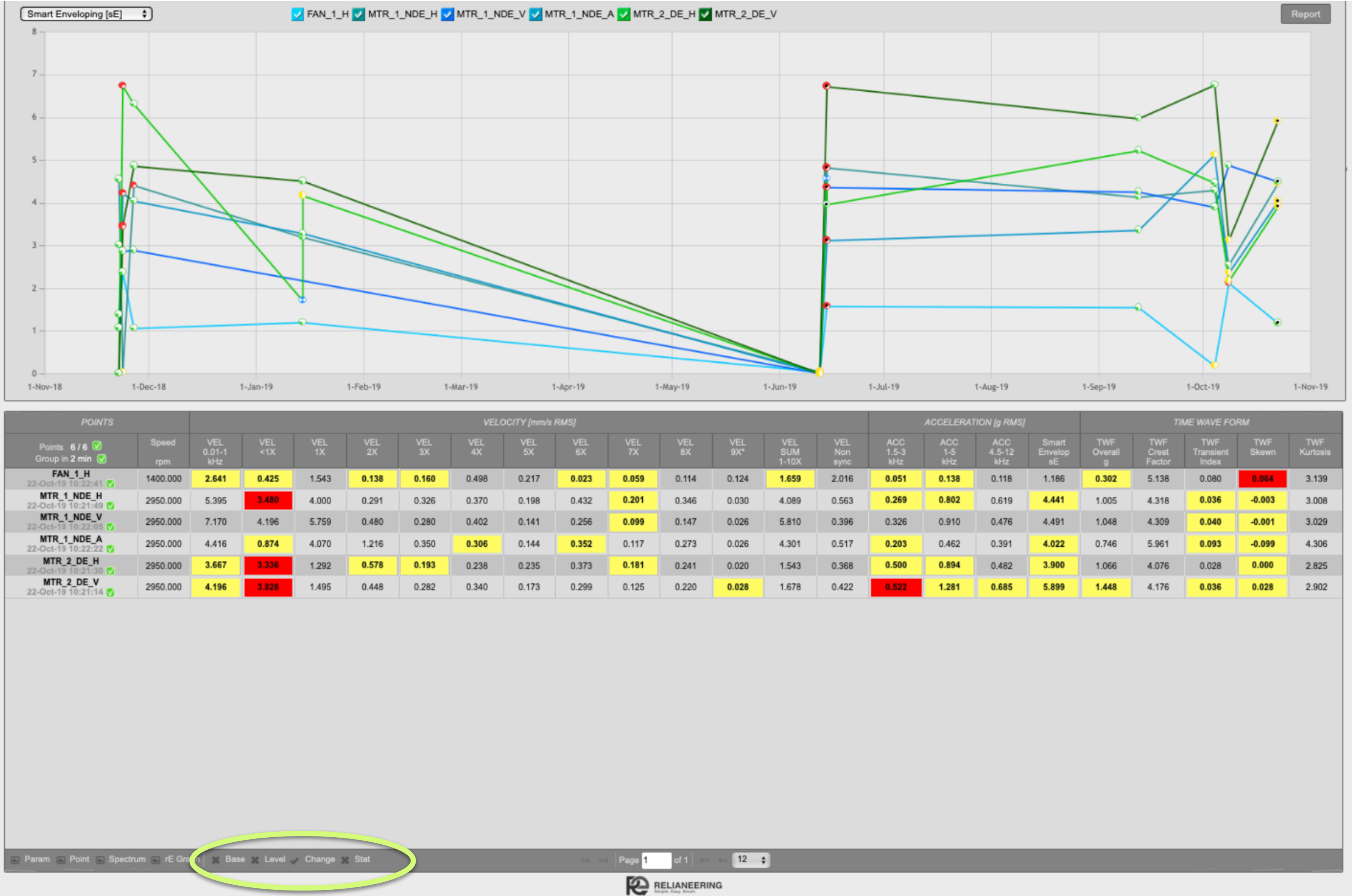

Deviation from the statistical standard deviation.

- Level - OFF.
- Baseline - OFF
- Change - OFF
- **Statistical - ON**

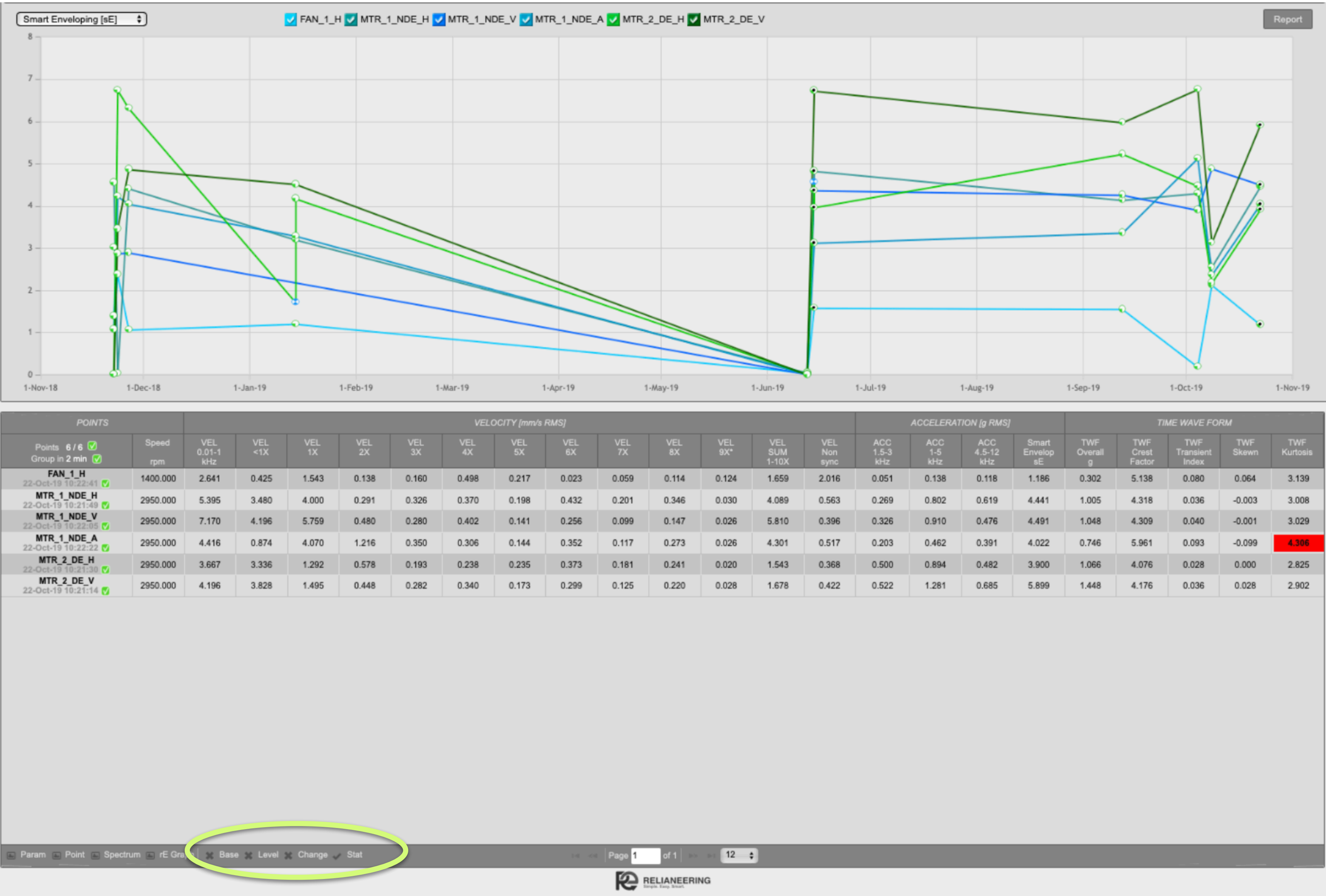

The ReSES.net platform allows trend comparison of all parameters from one CM Point.

The multi-parameter trend allows to define more precisely the stage of the bearing defect.

When the Viewer opens the multi-parameter plot, by default only overall vibration trend plus another four bands, 1X, 2X, 3X, and 4X will be displayed.

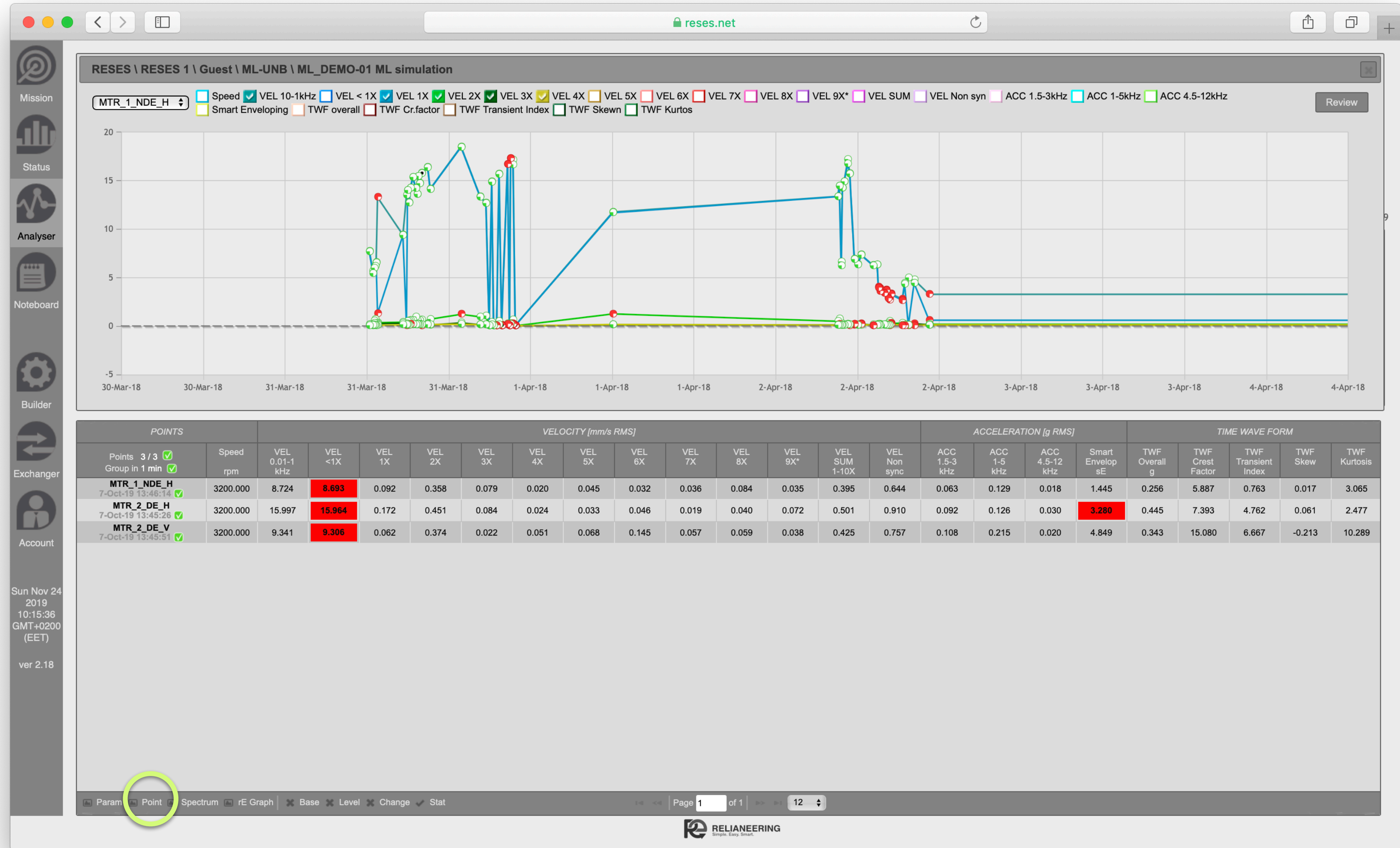

Spectrum plot

- The Viewer can select one of three predefined spectrum:
 - Velocity spectrum 0-1000 Hz 1600 lines (4 averages)
 - Acceleration 0-12000 Hz 12560 lines (no average)
 - sE (Smart Enveloping) 0-2000 Hz, 3200 lines
- The Viewer can plot the TWS 3s
- The scale is always in Hz
- The user can compare spectrums between points
- The cursor shows Hz, CPM, Amplitude and Order
- The Viewer can see a component specific frequencies (up to 5 frequencies per component)

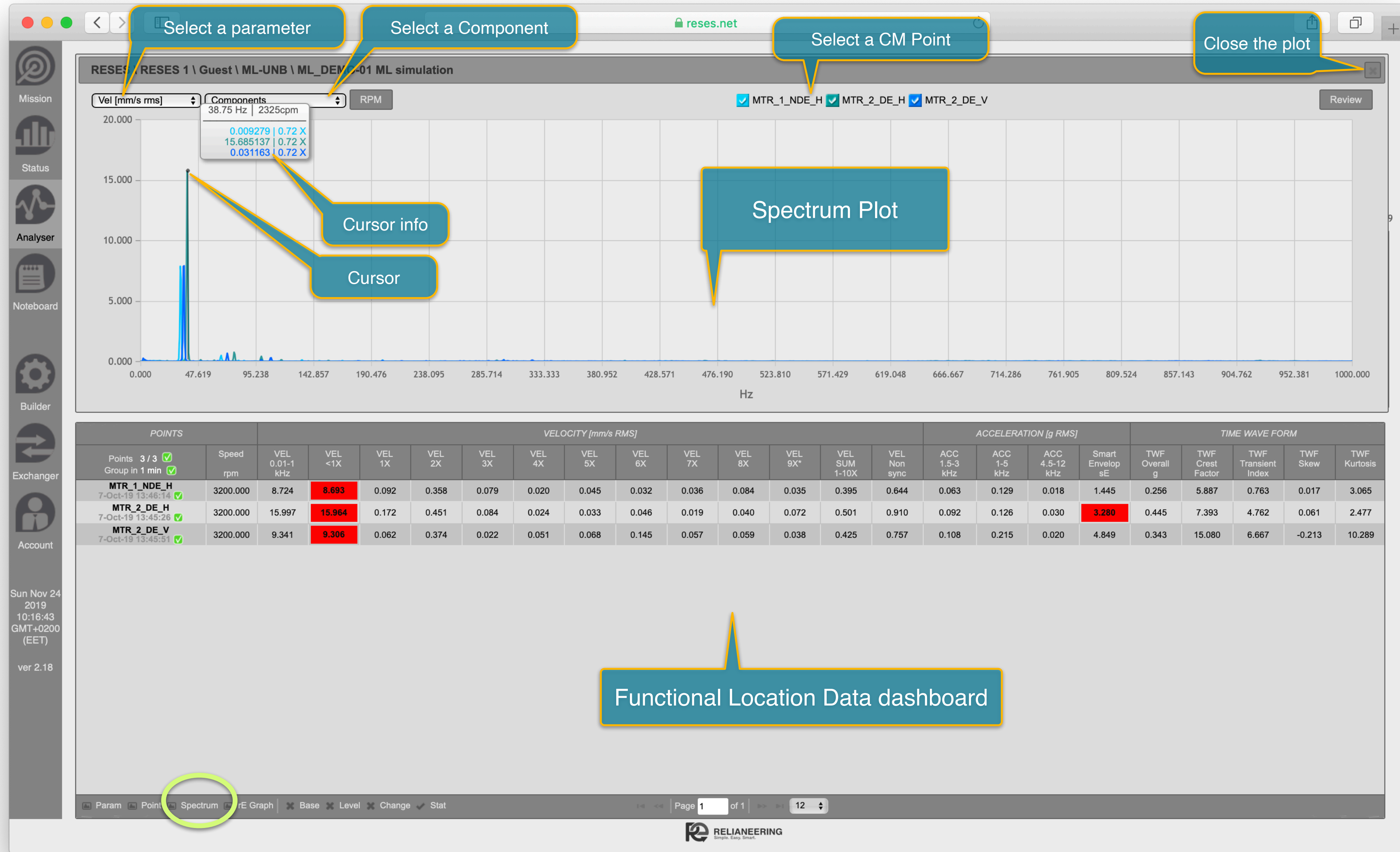

Tip

The Viewer with double click on the graph dot/cursor - point makes the frequency fundamental/reference frequency and automatically sees it harmonics

- Moving the cursor the user gets information about:
 - Absolute frequency in Hz
 - Relative frequency from the fundamental (*), sideband
 - Order of fundamental frequency (*)
 - The absolute and relative frequency in CPM
- Per each point the user gets:
 - Amplitude
 - Percentage of fundamental
 - Order of running speed
 - Order to fundamental frequency (*), sideband order

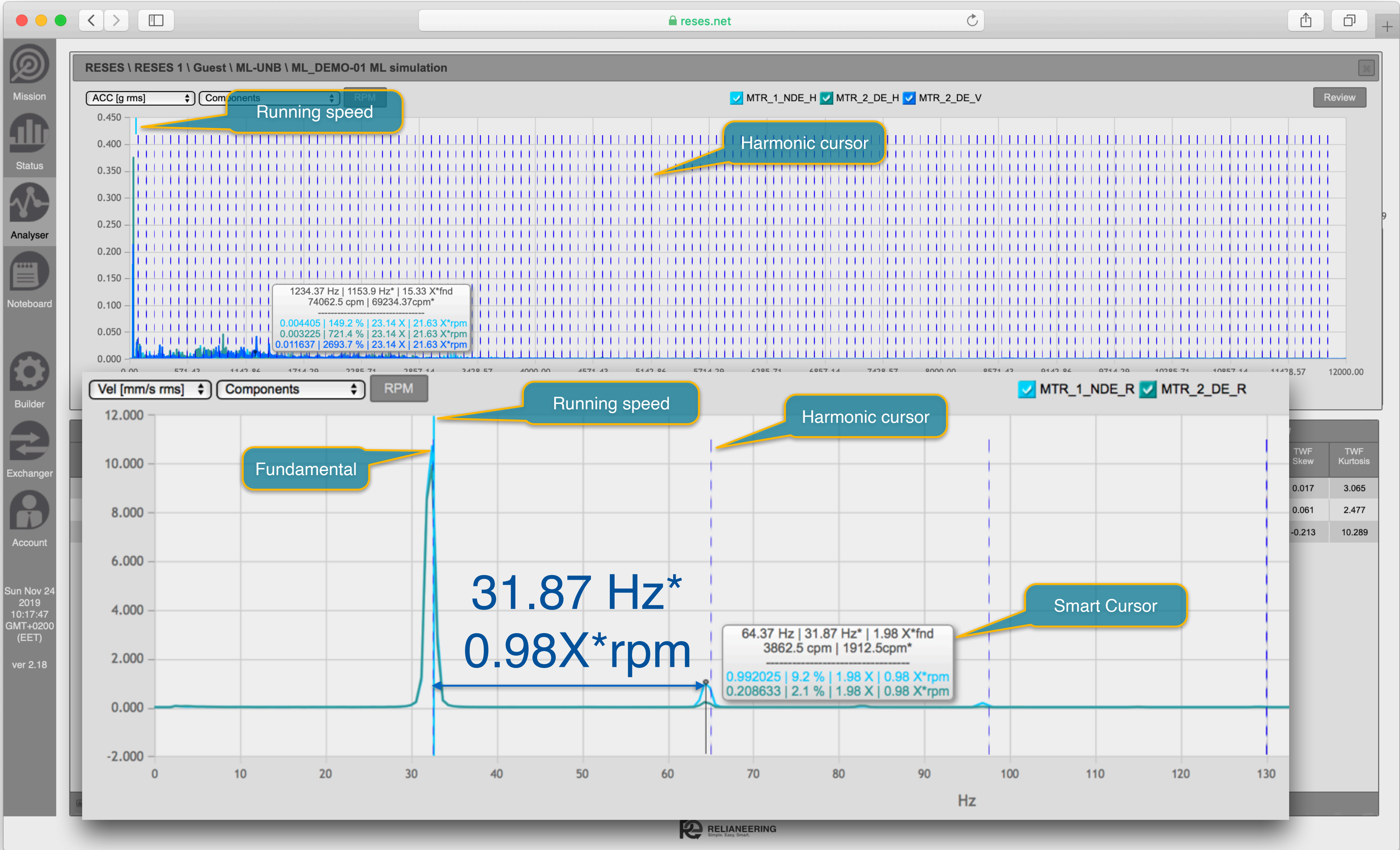

Tip

Select a component to look for a component's fault frequencies on the spectrum.

When you move the cursor automatically information about fault frequencies is updated.

When the selected frequency is an even number, with narrow tolerances, it will be colored in green.

Hold the cursor over the component frequency line to get information about the name.

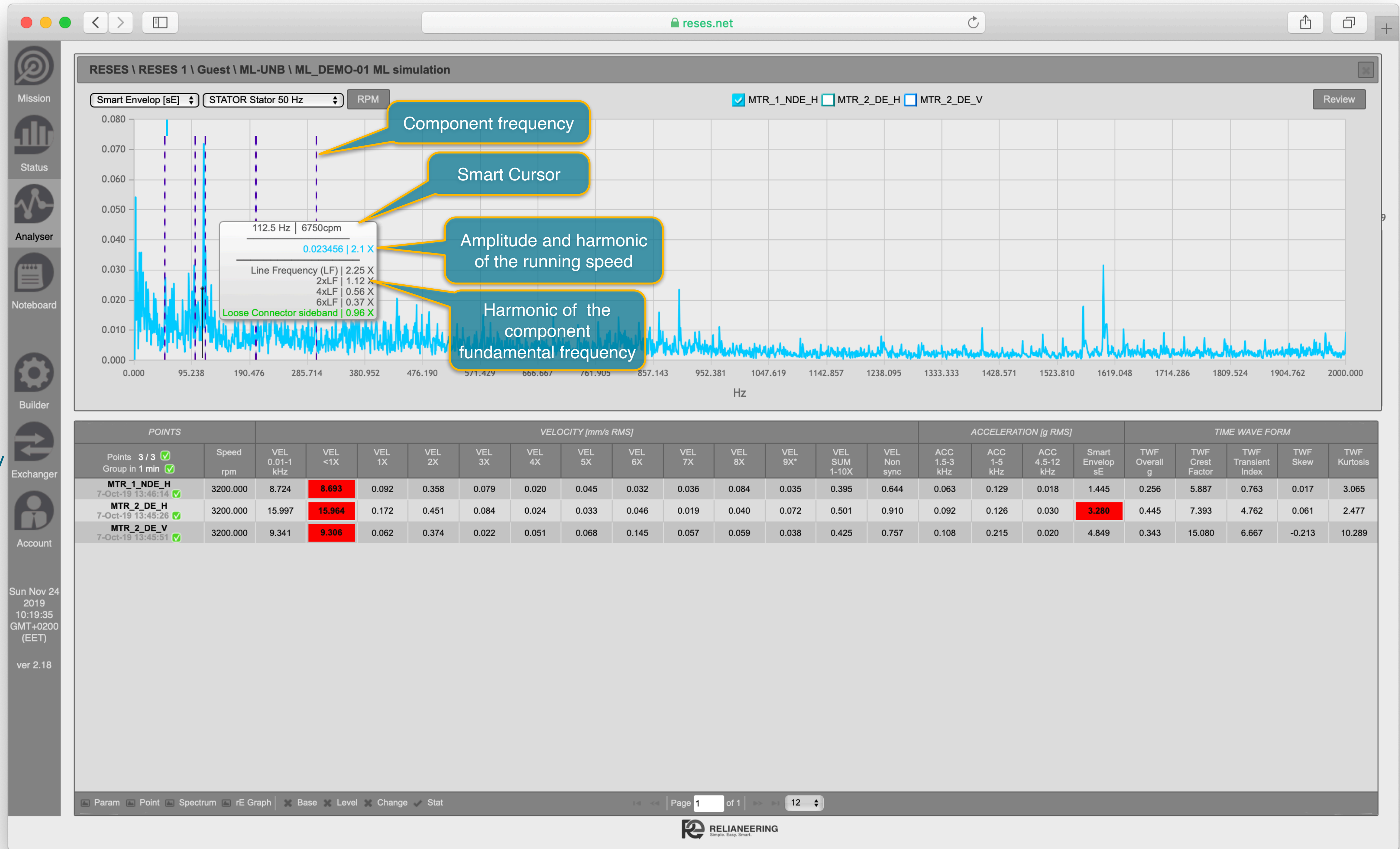

Time waveform

- The Viewer can open the TWF in the Spectrum plot
- By default only one point is downloaded, due to time consuming and only two points can be compared
- By double click of the selected point the user makes it reference time and see 10 cycles marked by vertical lines
- The Smart cursor gives information about:
 - Absolute amplitude and time in ms
 - Relative distance from the reference in ms, Hz and CPM
 - Percentage from the reference amplitude.
 - Relative distance in cycles

The screenshot displays the ReSES.net ANALYZER interface. At the top, the browser address bar shows 'reses.net'. The main window title is 'RESES \ RESES 1 \ Guest \ ML-UNB \ ML_DEMO-01 ML simulation'. Below the title, there are controls for 'TWF [g]' and 'RPM', and checkboxes for 'MTR_1_NDE_H', 'MTR_2_DE_H', and 'MTR_2_DE_V'. A 'Review' button is in the top right.

The central plot shows a time waveform (TWF) in blue. The y-axis ranges from -1.380 to 2.120 g, and the x-axis ranges from 0.00 to 3000.02 ms. A 'Smart Cursor' is positioned over a peak, displaying the following data: 691.9 ms | 32.5 ms*, 30.6 Hz | 1841.3 cpm, and -0.096989 | -62.8 % | 1 cycles 265°.

Below the plot is a data table with columns for POINTS, VELOCITY [mm/s RMS], ACCELERATION [g RMS], and TIME WAVE FORM. The table contains three rows of data for different points.

POINTS	Speed rpm	VELOCITY [mm/s RMS]													ACCELERATION [g RMS]				TIME WAVE FORM				
		VEL 0.01-1 kHz	VEL <1X	VEL 1X	VEL 2X	VEL 3X	VEL 4X	VEL 5X	VEL 6X	VEL 7X	VEL 8X	VEL 9X*	VEL SUM 1-10X	VEL Non sync	ACC 1.5-3 kHz	ACC 1-5 kHz	ACC 4.5-12 kHz	Smart Envelop sE	TWF Overall g	TWF Crest Factor	TWF Transient Index	TWF Skew	TWF Kurtosis
MTR_1_NDE_H 7-Oct-19 13:46:14 ✓	3200.000	8.724	8.693	0.092	0.358	0.079	0.020	0.045	0.032	0.036	0.084	0.035	0.395	0.644	0.063	0.129	0.018	1.445	0.256	5.887	0.763	0.017	3.065
MTR_2_DE_H 7-Oct-19 13:45:26 ✓	3200.000	15.997	15.964	0.172	0.451	0.084	0.024	0.033	0.046	0.019	0.040	0.072	0.501	0.910	0.092	0.126	0.030	3.280	0.445	7.393	4.762	0.061	2.477
MTR_2_DE_V 7-Oct-19 13:45:51 ✓	3200.000	9.341	9.306	0.062	0.374	0.022	0.051	0.068	0.145	0.057	0.059	0.038	0.425	0.757	0.108	0.215	0.020	4.849	0.343	15.080	6.667	-0.213	10.289

At the bottom of the interface, there is a navigation bar with 'Param', 'Point', 'Spectrum', 'rE Graph', 'Base', 'Level', 'Change', and 'Stat' buttons. The footer shows 'Sun Nov 24 2019 10:20:22 GMT+0200 (EET) ver 2.18' and the 'RELIANEERING' logo with the tagline 'Simple. Easy. Smart.'

ReSES.net ANALYZER \ rE Graph

The rE Graph is unique plot that allows the Viewer quickly to find which band contributes to the sE spectrum.

The plot uses a temperature colors to represent the amplitudes.

The straight vertical lines are signatures for potential faults.

The horizontal density areas show the frequency range where the fault is present.

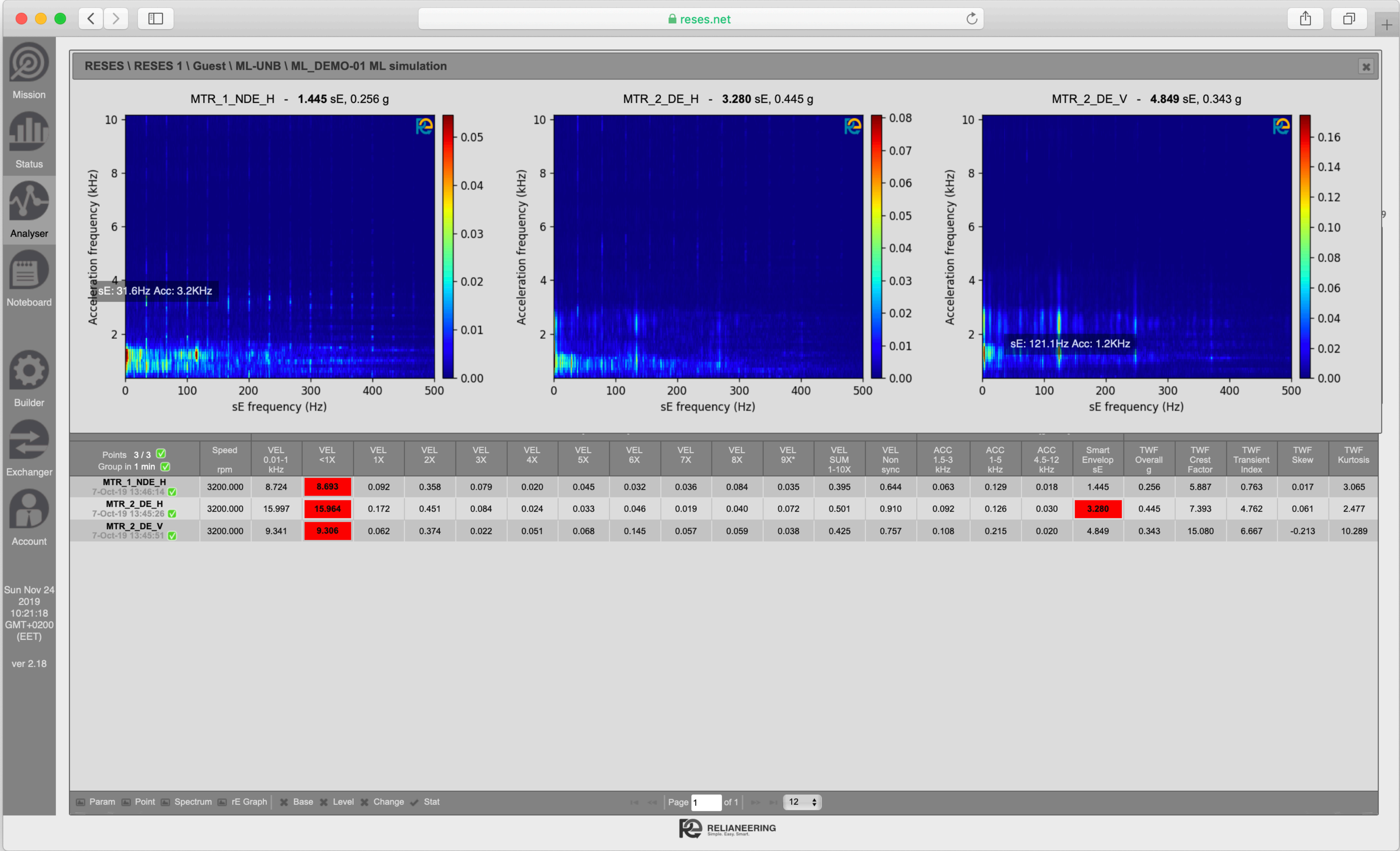

The Viewer can use the Builder to get more information about:

- Site Hierarchy
- Functional Location properties
- Equipment data
- Component data
- CM points alarm levels (9999 means no level alarm)

The screenshot displays the ReSES.net Builder interface with several windows open:

- Edit Process Unit:** Shows fields for Process Unit (Power Plant), Description (Test plan), GEO Location (Below deck 4), Movable asset (Yes), Type (4), and Surveyor organisation (LR).
- Edit System:** Shows fields for System (SYSTEM SW), Description (Sea Water system), Location (Compartment 3 and 4), CMMS ID (11), and Criticality (Very Low).
- Edit Functional Location:** Shows fields for Functional Location (Test Pump 2), Description (test machine), Location (none), CMMS ID (3), Criticality (Very Low), Notes (4), Data Collection Schedule in days (30), Analysis Schedule in days (40), ReSES Model (TEST_PMP_VER_3), Function (Sea Water), and Alarm Set (ISO 10816-3 0.3-50 MW Flexible).
- Edit Point:** Shows a table of alarm levels for MTR 1 NDE H. The Point RFID is 01121B8C54D0. A callout points to this field as the "RFID TAG".
- Edit Equipment:** Shows fields for Description (2 rolling bearings), Location, CMMS ID (1), Power [kW] (85.00), CM Speed [rpm] (3300), Plate Speed [rpm] (0.00), Criticality (Very Low), Manufacturer Model (0), Manufacture (0), and Serial Number (0). A callout points to the CMMS ID field as the "CUP ID".
- Equipment Table:** A table listing equipment components like GRINDER, DISC, ROTOR, and STATOR.
- Point Table:** A table listing points like MTR_1_NDE_H, MTR_2_DE_H, and MTR_2_DE_V with their corresponding Point RFIDs.

Exchanger

The Viewer can use Exchanger to extract information and post-process for different needs.

- Site's Functional Location (FL) list in CSV format
- Site's CM Status in CSV format
- FL's CM Status in PDF report
- FL's CM Points - as list in CSV format and their raw data
- FL's fault history in CSV format

The screenshot displays the ReSES.net EXCHANGER interface. The main table lists various process units and their associated systems and functional locations (FLs). The interface includes a sidebar with navigation options like Mission, Status, Analyser, Noteboard, Builder, Exchanger, and Account. The bottom of the interface shows the Reliance Engineering logo and the tagline 'Simple. Easy. Smart.'

Process Unit	System	FL Name	Last Status	Data Alarms	Last Data	Last Analysis	Last Recommendations	Feedback	Fault History	CM Status as
Guest	ML-UNB	ML_DEMO-01	▲	🔴	07-Oct-19	07-Oct-19	Balancing	n/a	CSV	PDF
Hotel Plant T	SYSTEM T1	FL D6 UH1801	▲	🔴	06-Jul-18	21-Sep-18	Replace	n/a	CSV	PDF
VisitShip	System T	GSW-1	▲	🔴	10-Nov-18	10-Nov-18	Visual Inspection; Other	n/a	CSV	PDF
Guest	Test F	TEST UNIT F1	◆	🔴	08-Feb-18	22-Nov-19	Balancing	n/a	CSV	PDF
Guest	Test F	TEST UNIT F2	◆	🟢	23-Aug-18	23-Aug-18	n/a	n/a	CSV	PDF
Hotel Plant T	SYSTEM T1	FL DND	◆	🔴	08-Nov-18	22-Nov-19	Grease analysis; Grease analysis; Grease analysis; Balanci	n/a	CSV	PDF
Power Plant T	SYSTEM SW	SW Pump 1	◆	🔴	21-Feb-19	21-Feb-19	Collect new data	n/a	CSV	PDF
Power Plant T	SYSTEM SW	SW Pump 2	◆	🔴	05-May-19	22-Nov-19	n/a	n/a	CSV	PDF
Power Plant T	SYSTEM SW	TFW V6	◆	🔴	26-Jun-19	22-Nov-19	n/a	n/a	CSV	PDF
VisitShip	System T	HFO_PRF_1	◆	🔴	13-Nov-18	22-Nov-19	n/a	n/a	CSV	PDF
Hotel Plant T	SYSTEM A/C	Pump 25633	■	🔴	15-Jan-19	22-Nov-19	n/a	n/a	CSV	PDF
Hotel Plant T	SYSTEM T1	FL D1 1809	■	🔴	24-Apr-19	26-Apr-19	n/a	n/a	CSV	PDF

Process Unit	System	Functional Location	CMMS ID	Last Analysis	CM Status as
Guest	ML-UNB	ML_DEMO-01 ML simulation	007-638-01	7-Oct-19	PDF
Guest	Test F	TEST UNIT F1 simulation	1234	22-Nov-19	PDF
Guest	Test F	TEST UNIT F2 simulation	F12-34	23-Aug-18	PDF
Hotel Plant T	SYSTEM A/C	Pump 25633 ver 4 signal test	1234567890	22-Nov-19	PDF
Hotel Plant T	SYSTEM A/C	testpmp		null	PDF
Hotel Plant T	SYSTEM T1	FL D1 1809 TEST Device HS	1	26-Apr-19	PDF
Hotel Plant T	SYSTEM T1	FL D2 UNIT 1 Test Grinder	RESES_001	21-Sep-18	PDF
Hotel Plant T	SYSTEM T1	FL D3 UNIT 2 second demo unit	1234ABCD0987	22-Oct-18	PDF
Hotel Plant T	SYSTEM T1	FL D5 UNIT 4		null	PDF
Hotel Plant T	SYSTEM T1	FL D6 UH1801 Demo Grinder	DEMO-3	21-Sep-18	PDF
Hotel Plant T	SYSTEM T1	FL DND test w/o machine	DEMO-41	22-Nov-19	PDF
Power Plant T	SYSTEM HFO	HFO_PRF_1C Purifier	12345	null	PDF

Point	Raw Data	Raw Data	Raw Data
MTR_1_NDE_H	LAST	LAST 10	1 YEAR
MTR_2_DE_H	LAST	LAST 10	1 YEAR
MTR_2_DE_V	LAST	LAST 10	1 YEAR

The ReSES.net platform offers unique communication feature for all people involved in the Site CBM activities.

Using the **Noteboard**, everyone can say something as a question, comment and can see who is active and who has access to the Site.

The Noteboard also gives information about the current traffic speed to reses.net

Tip: Do not use inappropriate language. Everything that you type will be recorded and seen by everyone.

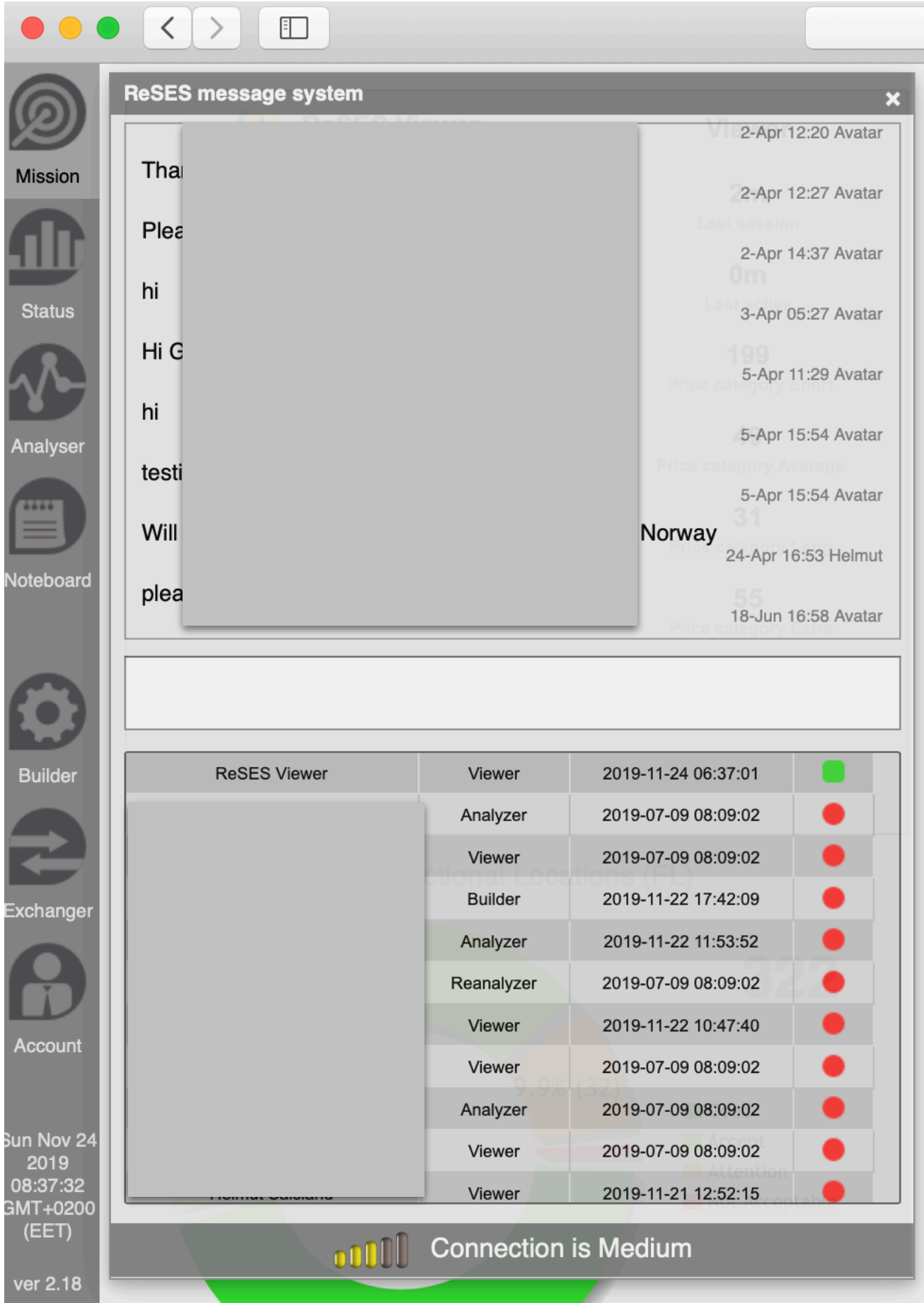

ReSES.net ACCOUNT

The **Viewer** can change the name and password, and photo at any time.

In the account the **Viewer** can find information about:

- Registration date
- Registered mail
- Days to expiration date

The **Viewer** can enter up to 3 more times after expiration date. In this case can see negative days to expire.

The **Viewer** can turn On/Off the option to receive weekly mail notifications about the data collection.

The **Viewer** can download manuals or other uploaded documents related to the Site.

The **Viewer** can send a request for support, too.

Tip

It is recommended the Viewer to Logout from the session.

The session stays open for 30 minutes, after closing the browser or in case of no activities.

The screenshot displays the ReSES.net account management interface. The browser address bar shows 'reses.net'. The interface is divided into several sections:

- User Profile:** Shows the email 'support@relianeering.com', registration date '2018-01-20 09:50:45', and last login '2020-03-18 14:16:41'. The user role is 'ReSES.View'. Options include 'Photo change', 'Name change', 'Password change', 'Account activate', and 'Logout'. A 'Temporary Activation Counter' shows '5' days remaining.
- Site Access Table:** A table with columns 'Company', 'Site', and 'Access'. The 'Access' column contains green status indicators.
- Documentation:** Links to 'Viewer Manual' and 'License Agreement' under 'Platform Documentation', and 'Company Documentation'.
- Contact Us:** A form with fields for 'Subject' and 'Message', and a 'Send email' button.
- Map:** A Google Map showing a location in Plovdiv, Bulgaria.
- Left Sidebar:** Navigation icons for Mission, Status, Analyser, Noteboard, Builder, Exchanger, and Account.
- Bottom Left:** System information: 'Wed Mar 18 2020 16:17:15 GMT+0200 (EET) ver 2.22'.
- Bottom Center:** 'RELIANEERING' logo and tagline 'Simple. Easy. Smart.'

Let's **together** replace
complexity with **Simplicity**